

# Munters Euroemme EM 30-36

## Air extraction fans

EM30 and EM36 are among the best-known exhaust box fans, able to combine high airflow capacity with reliability in any livestock farm (broiler, layer, swine, dairy) and greenhouse.

### Benefits

- Superior durability with M-Protect coating
- Reliable and robust, proven in the market
- High airflow capacity
- Energy efficient solution
- Suited for minimum ventilation

EM 30-36 are the ideal exhaust fans whenever a high and stable airflow is required, even in high static pressure environments. Both models feature extra strength against corrosion with housing, conveyor and shutter in M-Protect coated steel.

Their belt drive system enables low speed, to reduce energy consumption and noise, as well as to ensure a comfortable environment for animals and operators.

The patented centrifugal system provides an energy efficient solution and powerful springs keep shutters tightly closed when the fan is not turned on, avoiding air leakage and blocking light.

As the market leader in ventilation solutions for more than 60 years, GrainProteinTech Climate Control & Air Treatment guarantees quality and is ISO 9001 certified.



EM36 front view



EM30 rear view



Proudly manufactured with 100% renewable energy in our plants in Italy

# Munters Euroemme EM 30-36

## Air extraction fans

### Dimensions

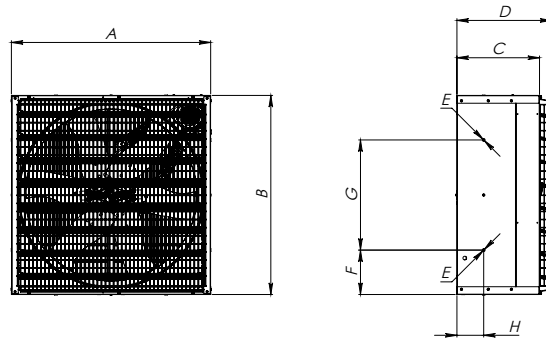

	A	B	C	D	E	F	G	H
EM30	950 mm	950 mm	450 mm	540 mm	M8	240 mm	475 mm	154 mm
EM36	1090 mm	1090 mm	450 mm	520 mm	M8	245 mm	600 mm	145 mm

### Technical specifications

		EM30			EM36		
Nominal power	hp	0.5	0.75	0.5	0.75	1.0	
Propeller diameter	mm [inch]	770 [30]			915 [36]		
Number of blades/material		6/M-Protect			6/M-Protect		
Number of shutter blades		7			8		
Motor/drive type		AC/Belt			AC/Belt		
Weight of fully equipped fan	kg	55	56	64	65	67	
Max power consumption/max current <sup>1</sup>	W/A	570/1.1	870/1.6	570/1.1	870/1.6	1150/2.1	
Max operating temperature	°C [°F]	50 [122]			50 [122]		
Max operating pressure	Pa	50			50		
Motor insulation grade/protective class		F/IP55			F/IP55		
Noise level <sup>2</sup>	Db(a)	63.4	66.9	62.1	63.9	68.4	

<sup>1</sup>50 Hz 400 V specification, 60 Hz available upon request, <sup>2</sup>Noise measure made according to ISO 3744

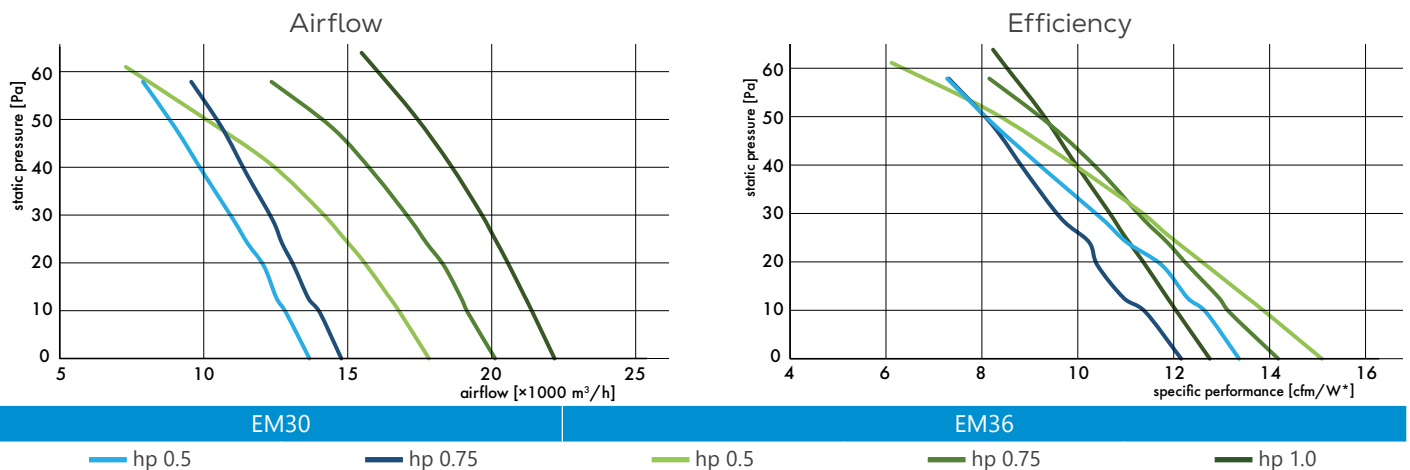

Airflow and efficiency tested in the test chamber in accordance with ANSI/AMCA 210/15 Standard, certified by BESS Lab. \*1 cfm/W = 1.7 (m³/h)/W

### Load capacity

	EM36		EM30
	Unassembled	Assembled	Assembled
20' container	170 (130 <sup>1</sup> )	50	60
40' container	-	104	120
40' HC container	300	104	120
13.6 m truck	360	120	140

Pyramidal mesh for installation below 2.7 m available upon request. <sup>1</sup>With CE plastic protection