

Munters Aerotech CX74

Circulation Fan

Features

- Munters Drive G2 Max offers the perfect combination of airflow and energy savings 57,500 thrust cfm and 25.3 thrust cfm/watt, best in its class
- Experience the power of Munters Drive, the longest-running EC motor technology in the industry, with over 35,000 drives sold worldwide, trust the experience
- Integrated control box: Enjoy hassle-free setup with plug-and-play programming, saving you hours of valuable set up time
- Belt Drive uses a premium efficiency motor to ensure top performance and longevity
- Propeller design maximizes airflow and centerline velocity
- Proudly designed and built in the USA with locally sourced components
- High quality fiberglass housing for a long lifespan and an oversized aerodynamic air intake provides the maximum airflow for a 74" propeller
- Chain or pipe mount hanging kits available for multiple ways to mount the fan, guard kit available separately

Munters CX74 Circulation fan is designed, engineered, and built in the USA for the demanding conditions of a modern dairy operation.

The advanced design of the CX74 housing produces a large volume of air and a higher centerline velocity, providing you with more control over the air movement in your barn. This allows you to direct the air to where you need it to reduce heat stress and bedding moisture for a happy healthy herd.

Achieve high wind speeds throughout the entire building or focus on specific areas where cows are located with the CX74 Circulation fan. The robust design provides quiet operation and the best airflow in its class.

CX74 is available with a belt drive or with Munters Drive G2 MAX:

- Lower electrical usage—saving up to 40% annually
- Qualifies for rebates from local utility companies
- Decreases the need for complex wiring systems
- Virtually maintenance-free



Fiberglass housing with gelcoat provides protection from UV and a lifetime of use.

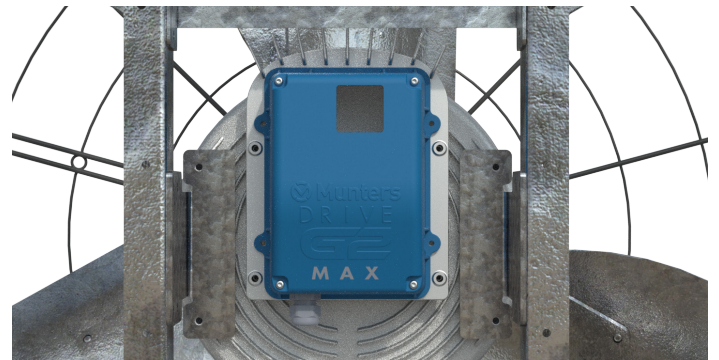

Munters Drive G2 MAX offers a truly plug-and-play setup, eliminating complex wiring and saving thousands in electrical installation costs.

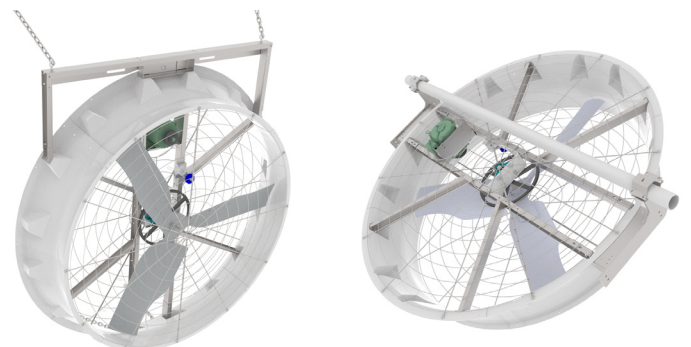

Optional top mount or pipe mount available to suit your barn design

Munters Aerotech CX74

Circulation Fans

Dimensions

Fan Diameter	A	B	C	Outside Diameter D
74"	90.75"	22.5"	17.5"	76.25"

Measurement diagram for reference only.

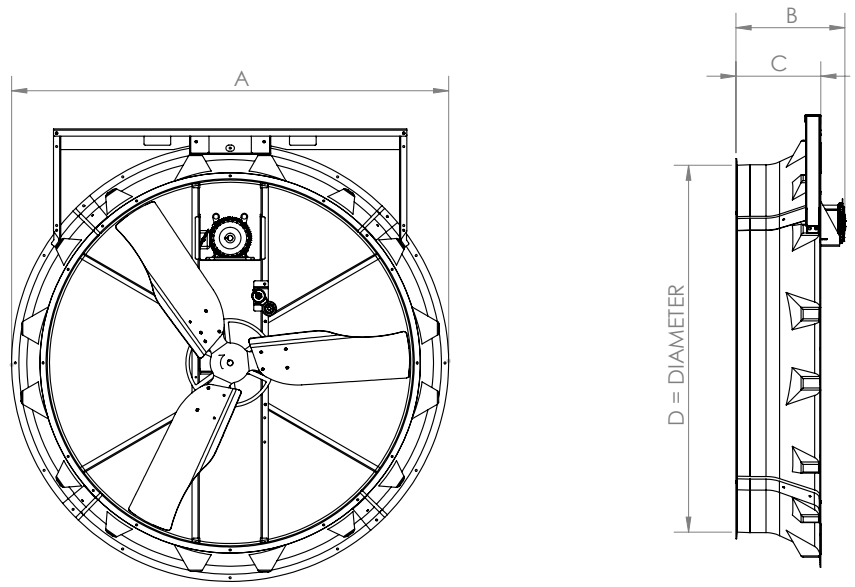

Performance[◊]

	Phase	Horse Power	Voltage	Volts (as tested)	Amps	Kilowatts	Airflow	Efficacy	Thrust	Thrust Efficiency Ratio	5D Centerline Velocity [◊]
CX74 Belt Drive	3	3	230/460	460	5.1	2.441	57,550	23.6	71.8	28.99	1,190
CX74 Munters Drive G2 MAX	3	3	460	460	4.3	2.27	57,500	25.3	71.7	31.58	1,190

[◊]Tested in accordance with AMCA Standard 210 & 230

Spread Profile

