

User Manual

Munters Aerotech CX74 Circulation Fan - Belt Drive

Models: CX743F3-1PK • CX743F3-2PK • CX743F3-3PK



CX74 Circulation Fan - Belt Drive

Instructions for Use and Maintenance

Thank You:

Thank you for purchasing a Aerotech[®] CX74 Circulation Fan. GrainProteinTech Climate Control & Air Treatment equipment is designed to be the highest performing, highest quality equipment you can buy. With the proper installation and maintenance it will provide many years of service.

Please Note:

To achieve maximum performance and insure long life from your Aerotech[®] product it is essential that it be installed and maintained properly. Please read all instructions carefully before beginning installation.

Warranty:

For Warranty claims information see the "Warranty Claims and Return Policy" form QM1021 available from the [Grain & Protein Technologies office at 1-800-227-2376](#) or by e-mail at info@climatecontrolairtreatment.com.

Conditions and Limitations:

- Products and Systems involved in a warranty claim under the "Warranty Claims and Return Policy" shall have been properly installed, maintained and operated under competent supervision, according to the instructions provided by Grain & Protein Technologies.
- Malfunction or failure resulting from misuse, abuse, negligence, alteration, accident or lack of proper installation or maintenance shall not be considered a defect under the Warranty.

Index

Chapters	Page
1. Unpacking the Equipment	4
1.1 Parts List	4
1.2 Fan Dimensions	5
1.3 Fan Accessories	5
2. Installation Instructions	6
2.1 Motor Mounting	6
3. Electrical Wiring	9
3.1 Electrical Wiring	9
3.2 Recommended Wire Routing	10
4. Operation	11
5. Maintenance	12
6. Troubleshooting	14
7. Exploded View and Parts List	15

Unpacking the Equipment

1.

Before beginning installation, check the overall condition of the equipment. Remove packing materials, and examine all components for signs of shipping damage. Any shipping damage is the customer's responsibility and should be reported immediately to your freight carrier.

1.1 Parts List

Each Fan includes:

- 1 - Belt Drive Fan
- 1 - Motor
- 1 - Motor Base
- 1 - Hardware Package as follows:

HP1268 - 74" Fan

ID	Qty.	Cat. No.	Description
[A]	4	KS1180	3/8"-16 x 1.5" Flange Bolt, ZP
[B]	4	KN0705	3/8"-16 Serrated Flange Hex Nut, ZP
[C]	6	KS1167	5/16"-18 x 1.25" SRTD HX Flange Bolt, ZP
[D]	6	KN0706	5/16"-18 Serrated Flange Hex Nut, ZP
[E]	1	FH2183	Sheave, AK46 x 1 1/8" Bore, w/Keyseat, CI
[F]	1	FH1521	V-Belt, A-section, Cogged

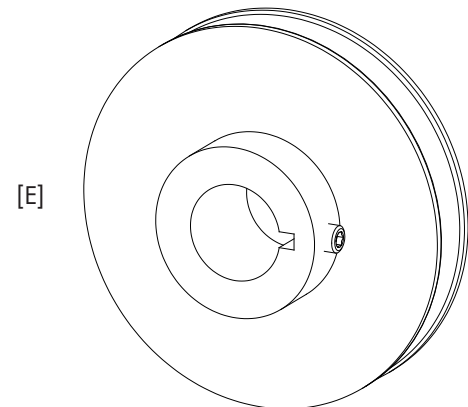
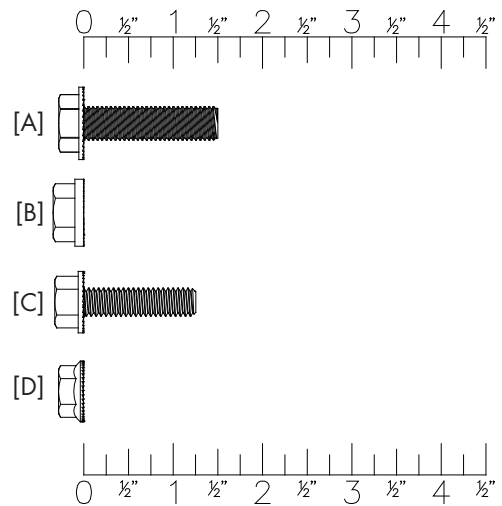

1.2 Fan Dimensions

Fan Specifications:

Hertz: 60

Phase: 3

HP: 3

Voltage: 208-230/460VAC

SF Amps:: 8.8/4.4

Weight: 300 lbs.

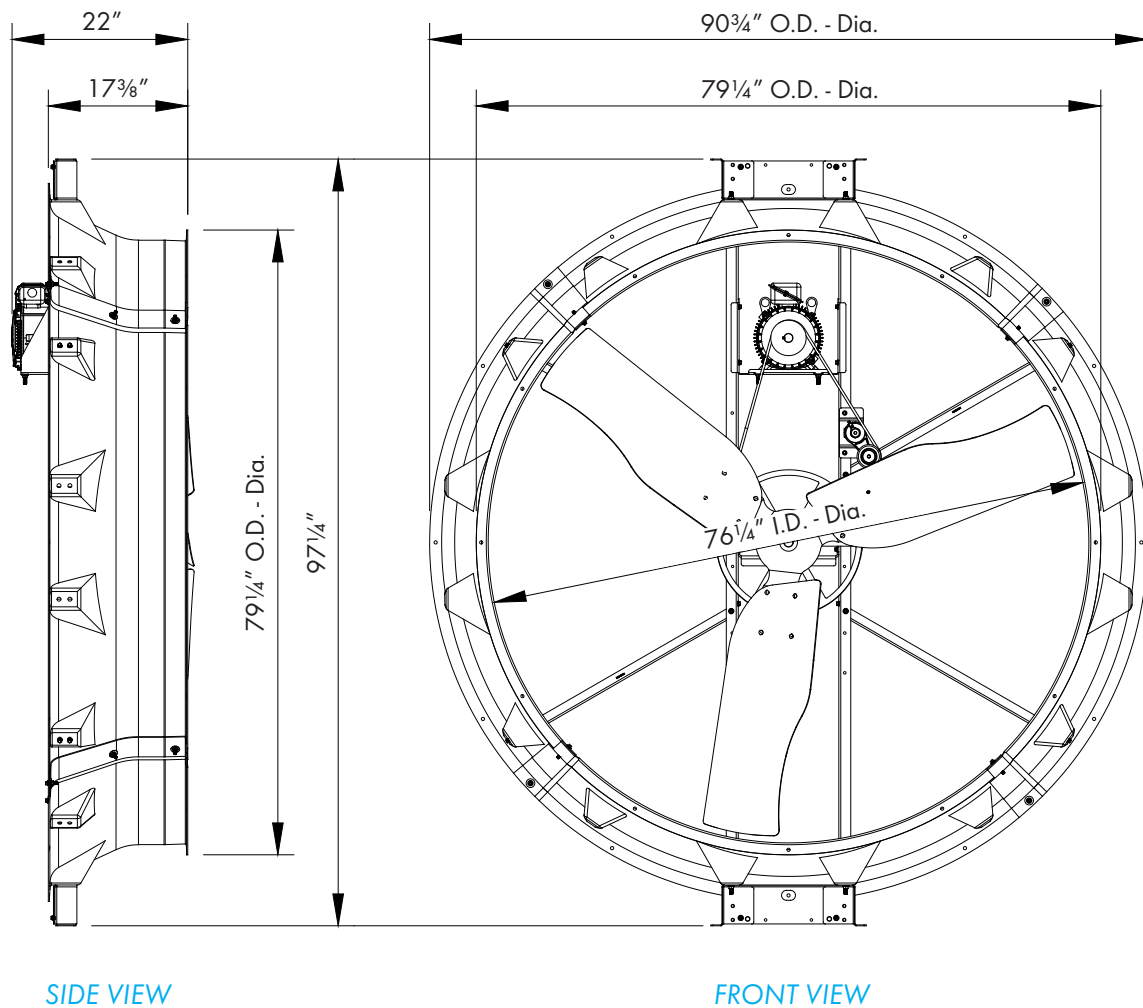

SIDE VIEW

FRONT VIEW

1.3 Fan Accessories

If any of the following accessories were purchased, refer to the corresponding manual for installation instructions:

74GK - Guard Kit - QM1239r1

FH1707 - Free Hanging Hanger Kit - QM1247r0

FH1709 - Pipe Hanging Kit - QM1249r0

Installation Instructions

2.

2.1 Motor Mounting

Step 1

Locate the Key provided with the Motor and place in Keyway on motor shaft. Place the Motor Sheave [E] on the Motor Shaft with the hub facing towards the motor and $\frac{5}{8}$ " of shaft protruding from the Sheave [E]. See Figure 1. ONLY tighten the set screw enough to hold the Sheave in place at this time.

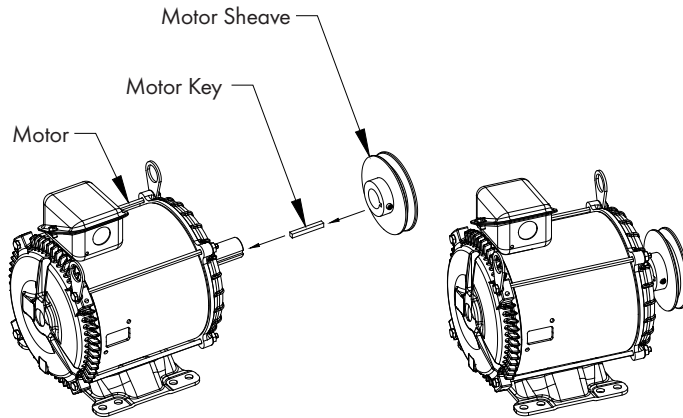

Figure 1A

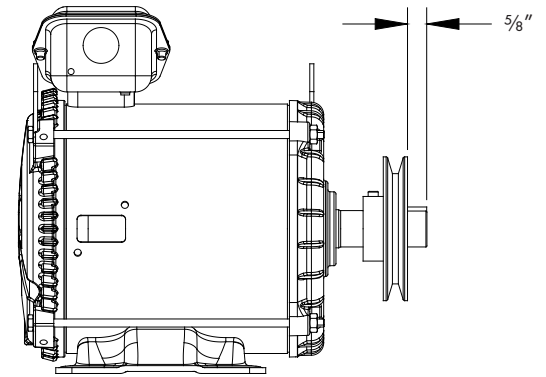

Figure 1B

Step 2

Install Motor Base between the main Fan Struts above the Bearings/Bearing Base and secure in place using (6) Bolts [C] and Nuts [D] and tighten to 18 ft.-lbs [24.5 N-m]. See Figure 2.

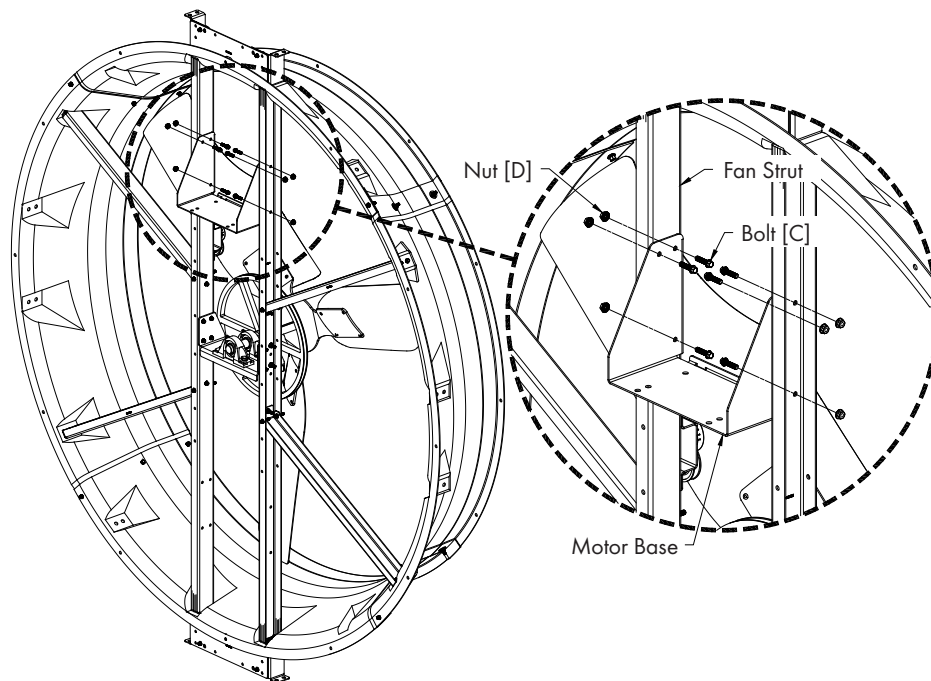

Figure 2

QM1241r2

Step 3

Place the Motor on the Motor Bracket and line up the rear holes on the Motor Base with the rear holes on the Motor Bracket. This should line up the 3rd pair of hole in the Motor Base with the front holes in the Motor Bracket. Secure Motor to Motor Bracket using (4) Bolts [A] and Nuts [B] and tighten to 37 ft.-lbs [50 N-m]. See [Figure 3](#).

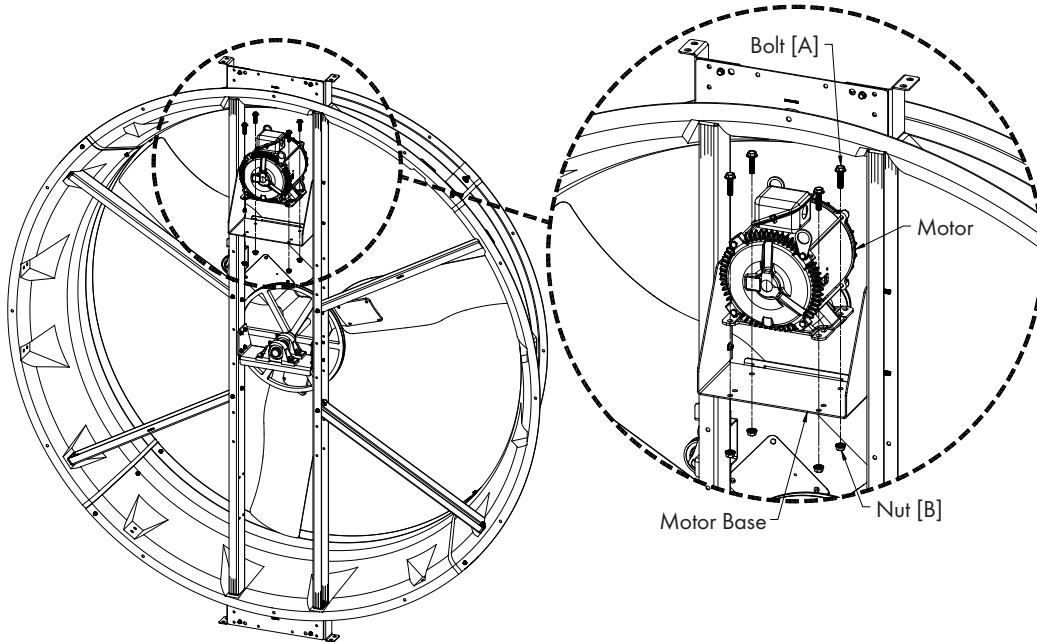

Figure 3

Step 4

Use a straight edge or level to check the alignment of Propeller Sheave, Tensioner Pulley and Motor Sheave. If needed adjust the position of Motor Sheave so the 3 pulleys line up. Once Motor Sheave is aligned tighten the set screw to 125 in-lbs [14 N-m] torque. See [Figure 4](#).

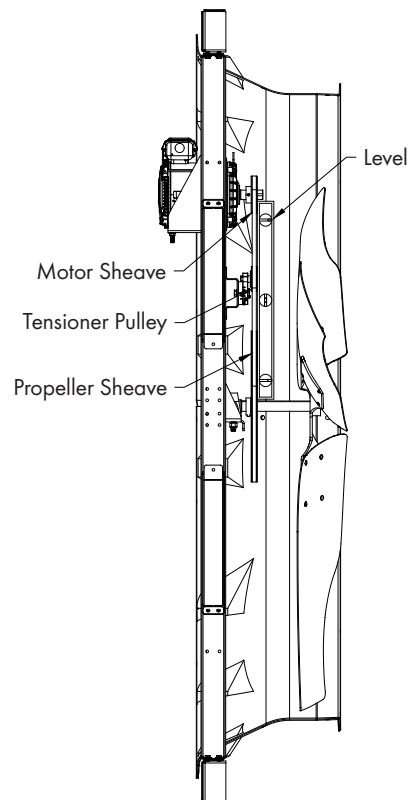

Figure 4

Step 5A

Slide V.-belt over Propeller and install by wrapping it around the 2 smaller pulleys and starting it over the larger Sheave. Continue rolling it onto the larger Sheave until it fits into groove. [See Figure 5A.](#)

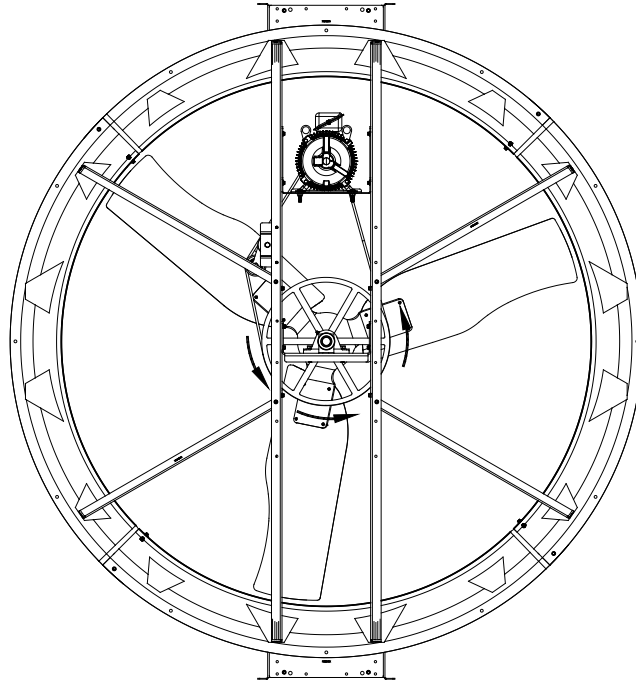

Figure 5A

Step 5B

To adjust belt tensioner to proper setting, loosen 10 mm bolt (using 17mm (1 1/16") end wrench) to allow tensioner arm to rotate. Working from outlet/prop side of fan, place a 27 mm (1 1/16") wrench onto the hex on the tensioner. Turn wrench counterclockwise until the single mark on base of belt tensioner is aligned with Mark 2 on tensioner arm. Hold tensioner at this setting and tighten the 10mm bolt on back of tensioner bracket to 40 ft.-lbs [54 N-m] torque. [See Figure 5B.](#)

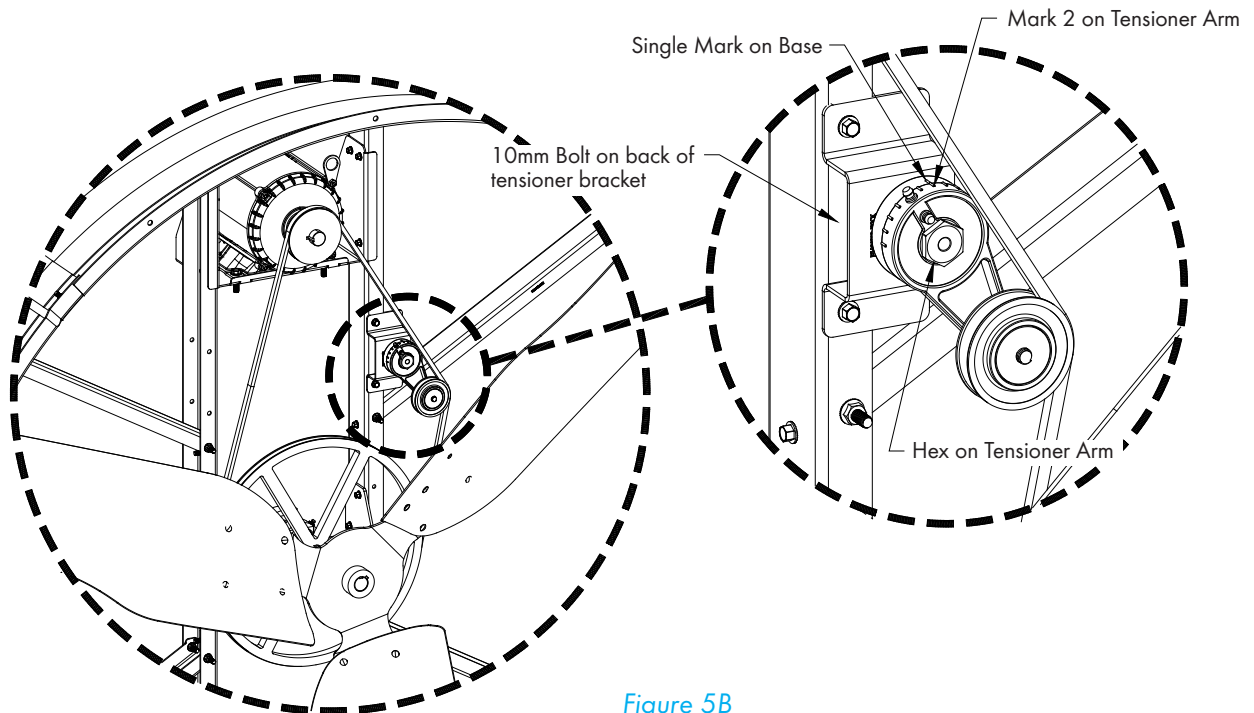

Figure 5B

QM1241r2

3.1 Electrical Wiring

All wiring should be installed in accordance with National, State, and Local electrical codes. Fans used to ventilate livestock buildings or other rooms where continuous air movement is essential should be connected to individual electrical circuits, with a minimum of two circuits per room. For electrical connection requirements, refer to diagram on motor nameplate and to information enclosed with the Munters environmental control to be used. After wiring check for proper motor rotation.

Three Phase Fans: motor overload protection should be provided for each fan. A three-pole motor starter or slow blow motor fuses must be used. See Figure 6.

If a frequency drive (inverter) is used, confirm that motors are rated for inverter duty at the voltage used. Shielded power cable between frequency drive and each motor is highly recommended. Installation of line reactors is recommended to reduce voltage spikes and harmonic distortion. Supplemental motor overload protection is also recommended.

NOTE: A safety cut-off switch should be located adjacent to each fan.

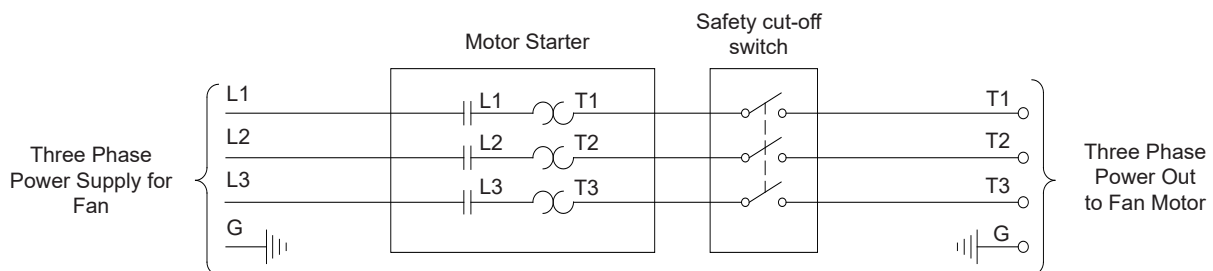

Figure 6

Three Phase - Motor Overload Protection with Disconnect

KEY:

- L1=Line 1
- L2=Line 2
- L3=Line 3
- H=Hot
- N=Neutral
- G=Ground

3.2 Recommended Wire Routing:

As the power cable exits the motor Electrical Box form a drip loop and then run power cable up along strut and "Zip" tie the cable to strut to prevent cable from getting tangled in the pulley or belt. See [Figure 7](#). Then run the cable to the circuit breaker or control panel.

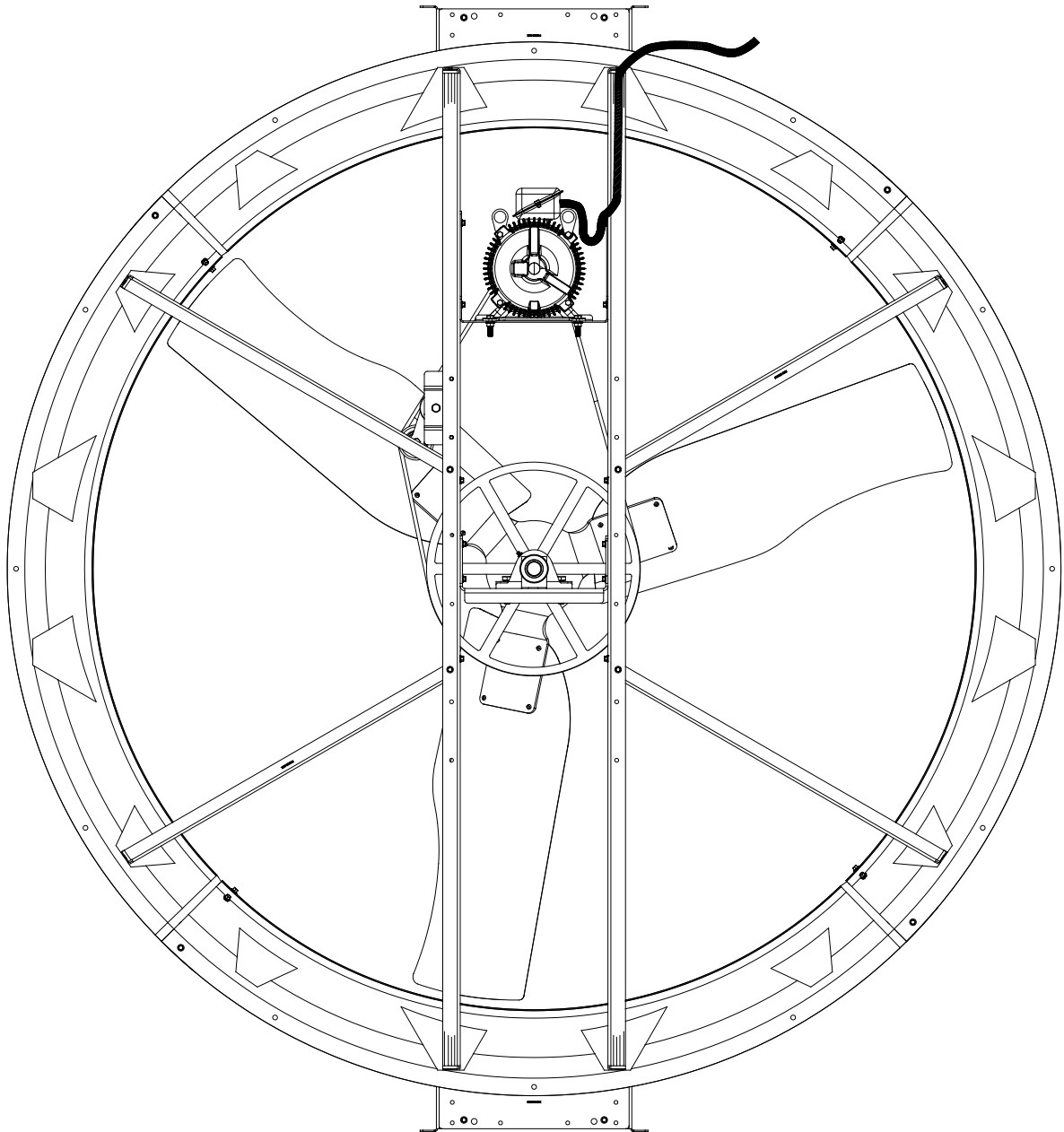

Figure 7

Operation

4.

4.1 Operation

INITIAL START-UP: With electrical power off, verify that the fan propeller turns freely and that all fasteners are secure. Turn on electrical power and confirm that the fan operates smoothly.

ADJUSTMENTS: Set the fan control to the temperature shown on your ventilations system drawing, or to a value which will provide the desired environmental conditions.

Three Phase Fans: If a frequency drive is used, the minimum operating frequency is 30 Hz.



5.1 Maintenance

The following inspection and cleaning procedures should be performed monthly:

Tools Needed for Maintenance:

wrenches: 13mm (1/2"), 17mm (1 1/16"), 27mm (1 1/16"), 5/32" Hex Key Wrench

- 1) **INSPECT PROPELLER:** Check that propeller is secure on prop shaft or motor shaft and that there are no signs of damage. The blades are of a self-cleaning design and should not require maintenance.
- 2) **CLEAN** regularly for best results:
 - **FAN MOTOR:** Remove any dust accumulation from motor using a brush or cloth. (DO NOT use a pressure washer). A clean motor will run cooler and last longer. At the same time, verify that the motor is secure in its mount.
 - **GUARD:** Clean any dust or feathers from fan guards using a brush. Dirty guards can reduce airflow.
- 3) **CHECK FASTENERS:** For safety, all fasteners should be inspected 1 month after initial operation and yearly thereafter. Tighten any loose connections.
- 4) **INSPECT FAN CONTROL:** With power disconnected, inspect all electrical connections. Wiring should be secure and in good condition. Remove any dust build-up from control case and sensor using a soft brush or cloth. **NEVER CLEAN ELECTRICAL EQUIPMENT WITH A PRESSURE WASHER!**
- 5) **GREASE BEARINGS:** Grease bearings every 4-6 months. Use no more than 2 shots when greasing fan.
 - A premium non-water based grease is recommended:
 - Shell Alvania #2
 - Exxon Unirex N2
 - Mobil 532
 - Mobil Mobilux #2
 - Texaco Premium RB
 - Texaco Multifak #2

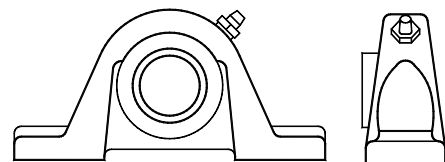

- 6) **CHECK DRIVE ALIGNMENT:** Check to make sure the belt is centered on the idler pulley, then use a straight edge to check the alignment of the drive pulleys. If an adjustment is needed, remove the belt, then loosen the set screw in one pulley and move it. Remember to tighten the set screw after making an adjustment. Drive alignment is very important for long belt life and proper operation.

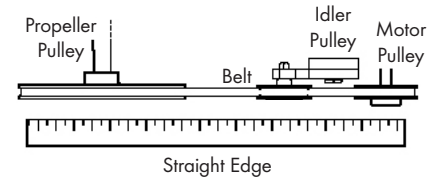

- 7) **CHECKING PULLEYS:** Roll the belt off and look at both pulleys. If the pulley has grooves in it or is no longer smooth, it needs replacement. A loose or slipping belt will reduce fan performance up to 60% and cause premature belt failure.

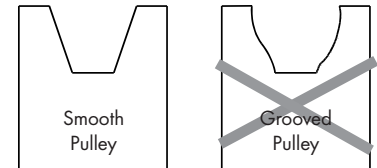

- 8) **BELT TENSIONING:** Check condition of belt, if worn, replace belt. If belt is in good condition then make sure the tensioner is in the correct position. Looking from the outlet/prop side of the fan, the correct position of the tensioner is approximately the 5 o'clock position. See Figure 8A.

To adjust belt tensioner to proper setting, loosen 10 mm (1 1/16"), bolt on back of tensioner bracket (using 17mm end wrench) to allow tensioner arm to rotate. Working from outlet/prop side of fan, place a 27 mm (1 1/16") wrench onto the hex on the tensioner. See Figure 5B. Turn wrench counterclockwise until the single mark on base of belt tensioner is aligned with Mark 2 on tensioner arm. Hold tensioner at this setting and tighten the 10mm bolt to 40 ft.-lbs [54 N-m] torque.

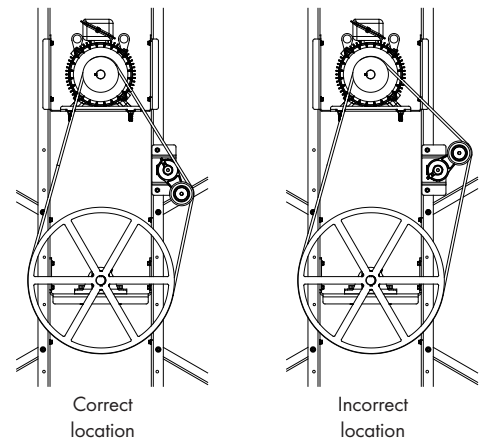

Figure 8A
Prop removed for clarity

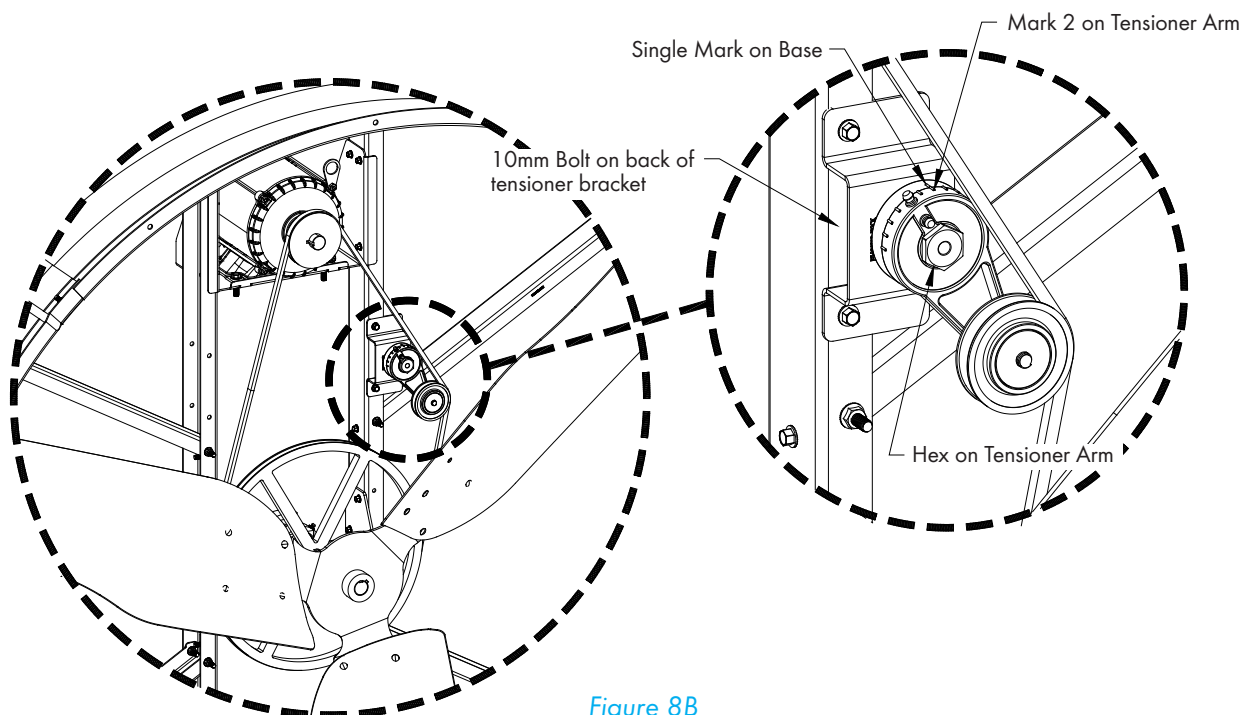
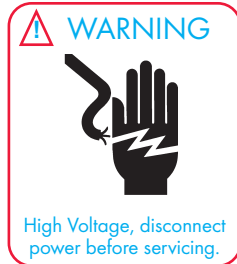

Figure 8B
QM1241r2

7.1 Troubleshooting



SYMPTOM	POSSIBLE CAUSES	CORRECTIVE ACTION
Fan Not Operating	<ol style="list-style-type: none"> 1. Fan control set above room temperature 2. Blown fuse or open circuit breaker 3. Propeller blade contacting fan housing 4. Fan control defective 	<ol style="list-style-type: none"> 1. Set to a lower temperature 2. Replace fuse or reset breaker 3. Realign motor in fan housing 4. Repair or replace control 5. Repair or replace motor
Fan Operating- Insufficient Airflow	<ol style="list-style-type: none"> 1. Shutter jammed or dirty 2. Guard dirty 3. Frequency drive improperly adjusted 4. Incorrect Belt Tension/worn belt 	<ol style="list-style-type: none"> 1. Unjam and clean shutter 2. Clean guard 3. See operation, Step 2 for adjustments guidelines 4. See Maintenance Section, Belt Tensioning
Excessive Noise	<ol style="list-style-type: none"> 1. Propeller blade contacting fan housing 2. Motor bearing or shaft bearing defective 3. Frequency drive improperly adjusted 	<ol style="list-style-type: none"> 1. Sand fan housing to remove high spot 2. Repair or replace motor or shaft bearings 3. See operation, Step 2 for adjustments guidelines
Excessive Vibration	<ol style="list-style-type: none"> 1. Motor loose on mount 2. Propeller damaged 	<ol style="list-style-type: none"> 1. Tighten fasteners 2. Replace propeller 3. Repair or replace motor or propeller shaft

Exploded View

7.

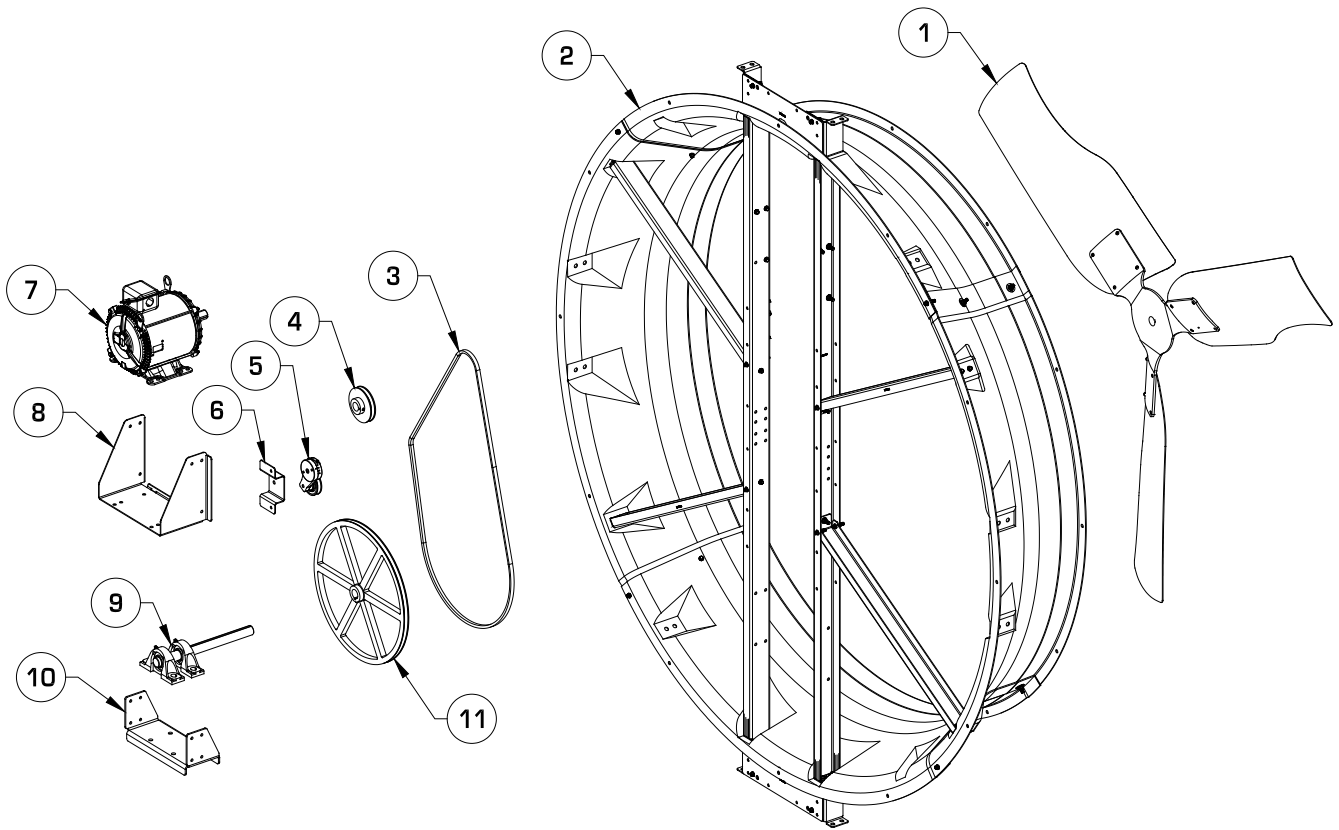

Item	Catalog No.	Description	Qty.
1	FP1874	Propeller, BD, 3-blade, 1.1875" Bore, Keyed, GZ	1
2	FH2375	Assembly, Orifice Panel with Struts, FG/GZ	1
3	FH1521	V-Belt, A-section, Cogged	1
4	FH2183	Motor Sheave, A-section, 1 1/8" Bore, w/ Keyseat, CI	1
5	FH2402K FH2406 FH2459	Belt tensioner assembly with 3" idler pulley 3" idler pulley only, with bolt Tensioner arm only, AL	1
6	FH2572	Mounting Bracket for Belt Tensioner, CX74, GZ	1
7	FM1063	Motor, 3HP, 1765 RPM, 182 FR, 3PH, 230/480V, 60Hz	1
8	FH2570	Motor Mounting Bracket, CX74, GZ	1
9	FH2378K	Assembly, Bearings/Shaft, w/pins, CX74, STL	1
10	FH2571	Bearing Mounting Bracket, CX74, CTD-STL, BLK	1
11	FH2185	Propeller Sheave, A-Section, 1 3/16" Bore, w/ Keyseat, CI	1



Munters Aerotech CX74 Circulation Fan is developed and produced by GrainProteinTech Climate Control Air Treatment US, LLC.

2691 Ena Dr., Lansing, MI 48917 | 1-800-227-2376

© 2025 GRAIN AND PROTEIN TECHNOLOGIES.

All rights reserved. GrainProteinTech Climate Control & Air Treatment reserves the right to change designs and specifications without notice.

www.climatecontrolairtreatment.com