



User Manual

Munters Aerotech Atlas74, 74" Munters Drive* Exhaust Fan

Model: ATS74D3F43CT-HO • ATS74D3F43CT-HE

*Protected by U.S. Patent No. US20230031171A1 and US11632932B2

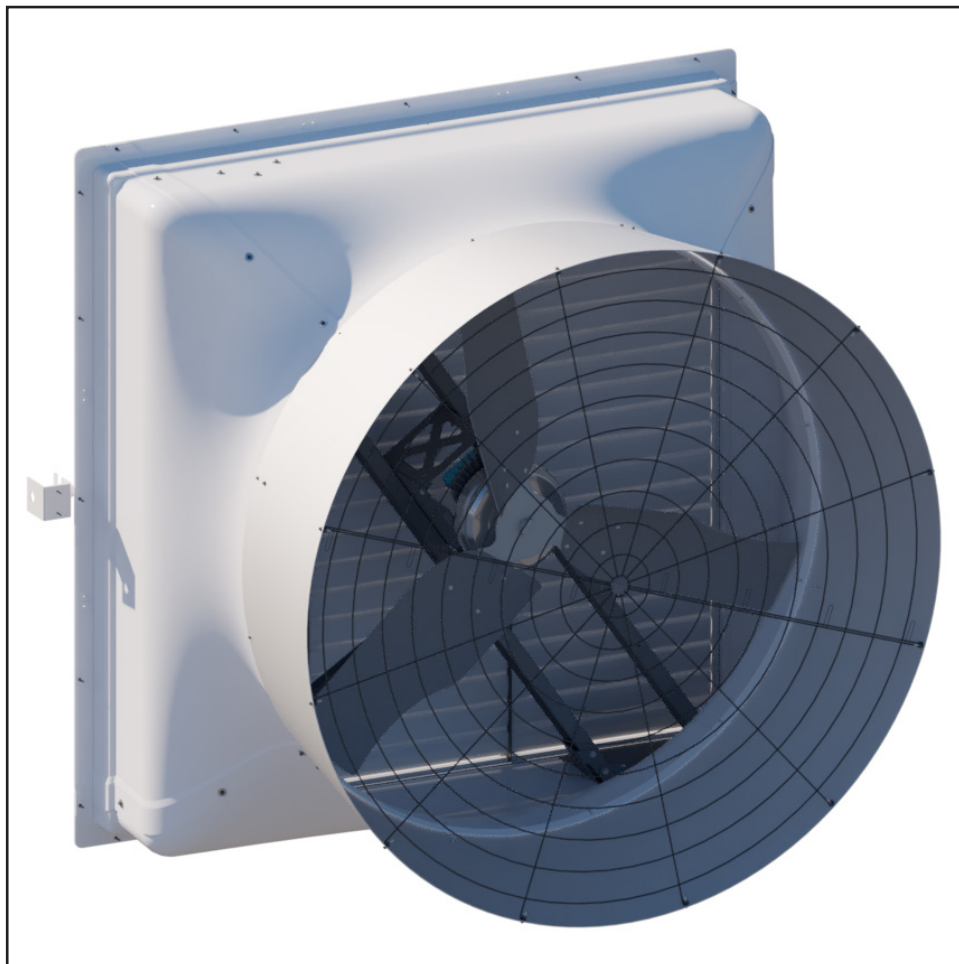

Atlas 74 Exhaust Fan

with Munters Drive

Instructions for Use and Maintenance

Thank You:

Thank you for purchasing a Aerotech[®] Atlas74 Exhaust Fan with Munters Drive. GrainProteinTech Climate Control & Air Treatment equipment is designed to be the highest performing, highest quality equipment you can buy. With the proper installation and maintenance it will provide many years of service.

Please Note:

To achieve maximum performance and insure long life from your Aerotech[®] product it is essential that it be installed and maintained properly. Please read all instructions carefully before beginning installation.

Warranty:

For Warranty claims information see the "Warranty Claims and Return Policy" form QM1021 available from the [Grain & Protein Technologies office at 1-800-227-2376](#) or by e-mail at info@climatecontrolairtreatment.com.

Conditions and Limitations:

- Products and Systems involved in a warranty claim under the "Warranty Claims and Return Policy" shall have been properly installed, maintained and operated under competent supervision, according to the instructions provided by Grain & Protein Technologies.
- Malfunction or failure resulting from misuse, abuse, negligence, alteration, accident or lack of proper installation or maintenance shall not be considered a defect under the Warranty.

Index

Chapters	Page
1. Unpacking the Equipment	4
1.1 Parts List	4
1.2 Fan Dimensions	5
1.3 Fan Spacing	6-7
2. Installation Instructions	8-17
2.1 Installation	8
2.2 Cone Installation	12
2.3 PT Shutter	15
2.4 Shutter Wind Kit	18
3. Electrical Wiring	20-25
3.1 Recommended Wire Routing	21
3.2 Three Phase Power Connection	22
3.3 Fan Operation with No Control	23
3.4 Fan Operation On/Off with Control	23
3.5 Fan Operation Off/Low/High	24
3.6 Fan Operation Off/Variable with 10-0V Signal	24
3.7 Fan Operation Off/Variable with Potentiometer	25
3.8 Fan Alarm Connections	25
4. Operation and Maintenance	26
5. Troubleshooting	27
6. Winterizing	28
6.1 Winterizing	28
6.2 Winter Weather Protection	28
7. Exploded View and Parts List	30-31

Unpacking the Equipment

1.

Before beginning installation, check the overall condition of the equipment. Remove packing materials, and examine all components for signs of shipping damage. Any shipping damage is the customer's responsibility and should be reported immediately to your freight carrier. Fan is shipped complete with all accessories.

1.1 Parts List

Each Fan includes:

- 1 - Munters Drive Fan
- 4 - Cone Sections, PL
- 2 - Guard Sections, CTD
- 1 - Shutter
- 2 - Shutter Wind Bracket, GZ
- 1 - Shutter Wind Pipe, GZ
- 4 - Reinforcing Ring, 1/4 Section, Atlas74, CTD-STL, White
- 1 - Hardware Package as follows:

HP1169 - Atlas 74

ID	Qty.	Cat. No.	Description
[A]	28	KS1167	5/16"-18 x 1.25" SRTD Flange Head Bolt, ZP
[B]	32	KN0706	5/16"-18 SRTD Flange Nut, ZP
[C]	12	KW3011	5/16" x 1 1/4" O.D. Flat Washer, SS
[H]	6	KS2105	#14 x 1.5" Hex Washer, Lag Screw, SS
[J]	6	KW3002	1/4" Type-A, Narrow Flat Washer, SS
[K]	6	FH2732	End Pivoting Shutter Clip, SS
	1	HP1202	Snow Ring Hardware Package
[D]	4	KS1169	5/16"-18 x 1.75" SRTD Flange Head Bolt, ZP
[E]	4	KN1706	5/16"-18 Nylock Nut, ZP

WARNING:

A Munters Lift Kit, FH1890, is required for installation of Atlas Fan. One Lift Kit may be used for multiple Atlas Fans. Failure to use the Munters Lift Kit may result in damage to fan. **DO NOT** use chains to lift fan for installation. Damage from chains will not be covered under warranty.

Each FH1890 Lift Bracket includes:

- 1 - Left Lift Bracket, PWDCTD
- 1 - Right Lift Bracket, PWDCTD
- 1 - Hardware Package as follows:

HP1891 - for FH1890

ID	Qty.	Cat. No.	Description
[F]	8	KS1180	3/8"-16 x 1.5" Flange Head Bolt, ZP
[G]	8	KN0705	3/8"-16 SRTD Flange Nut, ZP

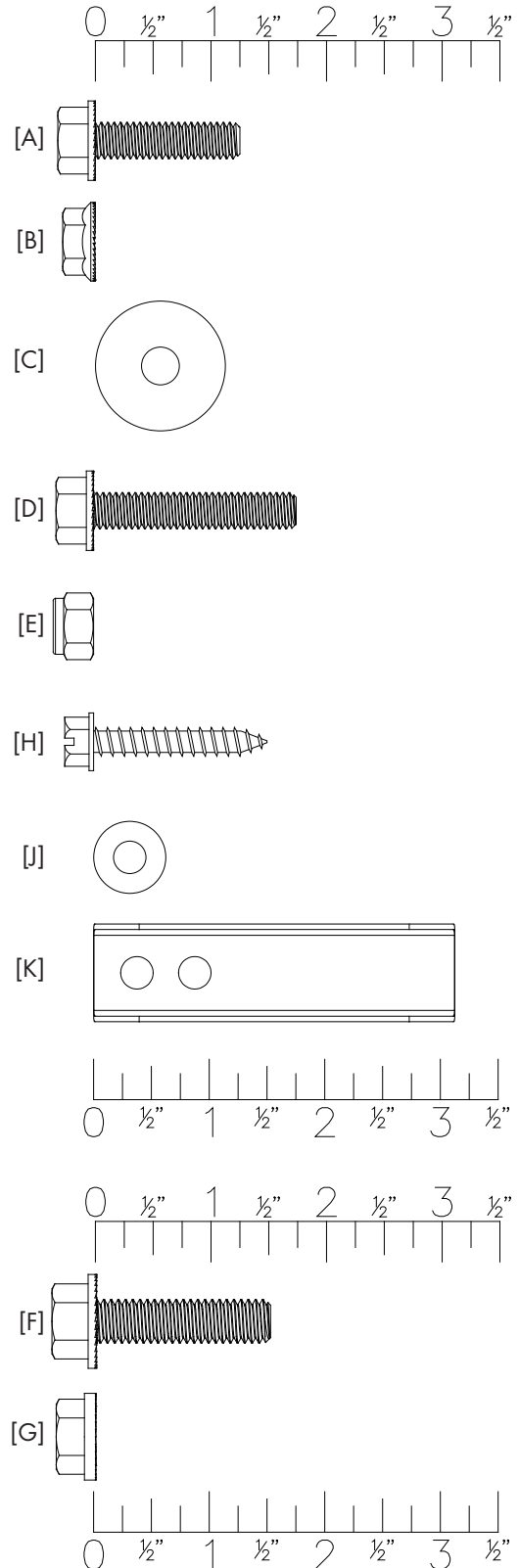

1.2 Fan Dimensions

Fan Specifications:

Hertz: 60

Voltage: 460VAC

Phase: 3

Weight: 400 lbs. [182 Kg]

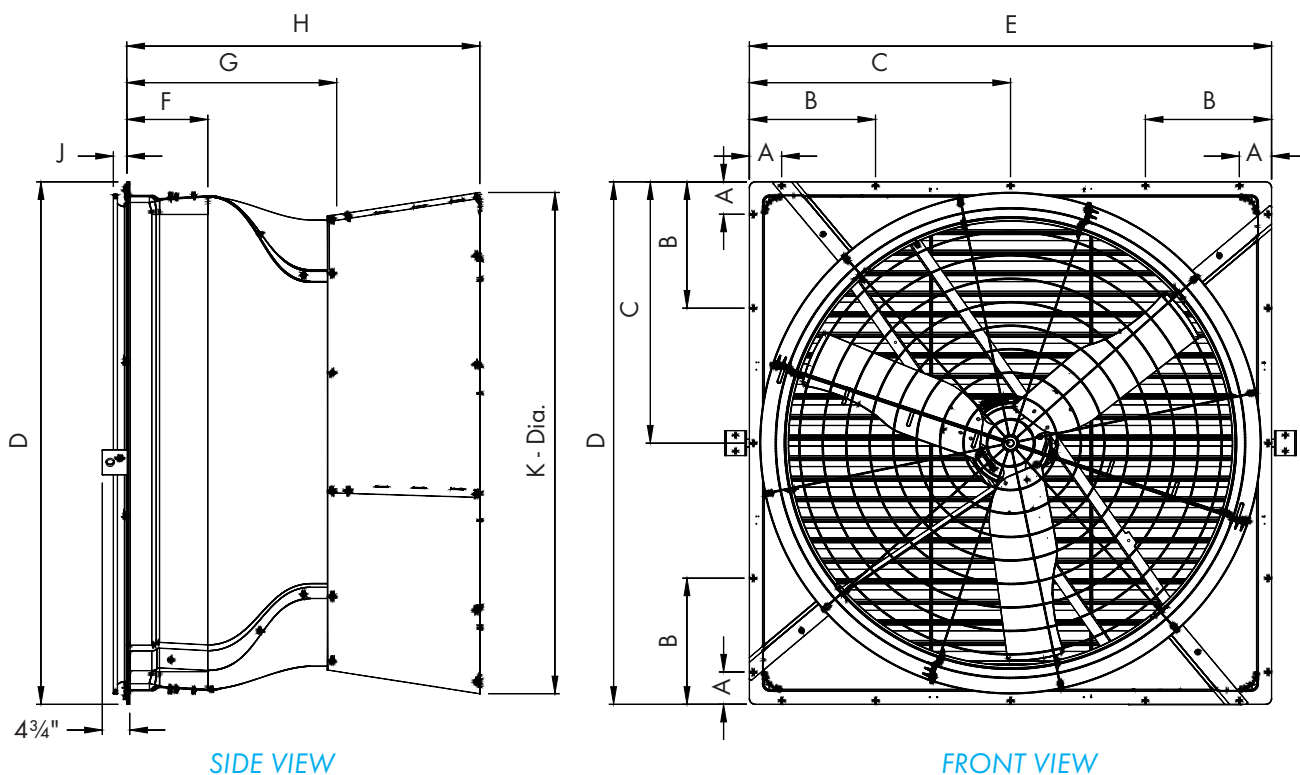

FAN DIA.	A	B	C	D	E	F	G	H	J	K-Dia.	WALL OPENING (I.D., framed)
74"	5 1/2"	21 1/2"	44 1/2"	89"	89"	13 7/8"	35 3/4"	60 3/16"	2 5/16"	85 3/8"	84 1/2"W. 84 1/2"H.

1.3A Recommended Fan Spacing

When determining fan spacing/fan layout, keep in mind that the fan requires $3\frac{3}{4}$ " clearance for the Wind Kit Bracket to be installed. If the fans are to be installed side-by-side with the Wind Kit Brackets adjacent to each other, the minimum fan spacing is 98" Center-to-Center. See Figure Below.

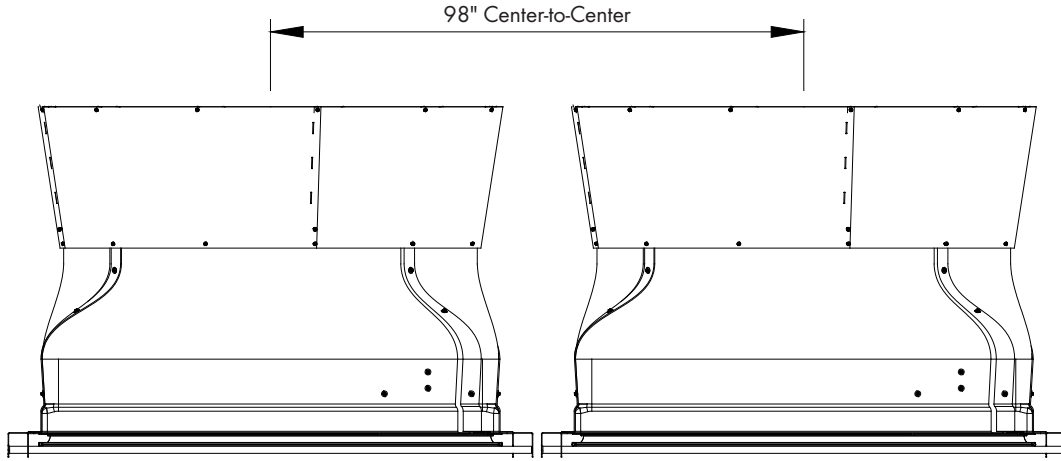

Top View
(Recommended Fan Spacing)

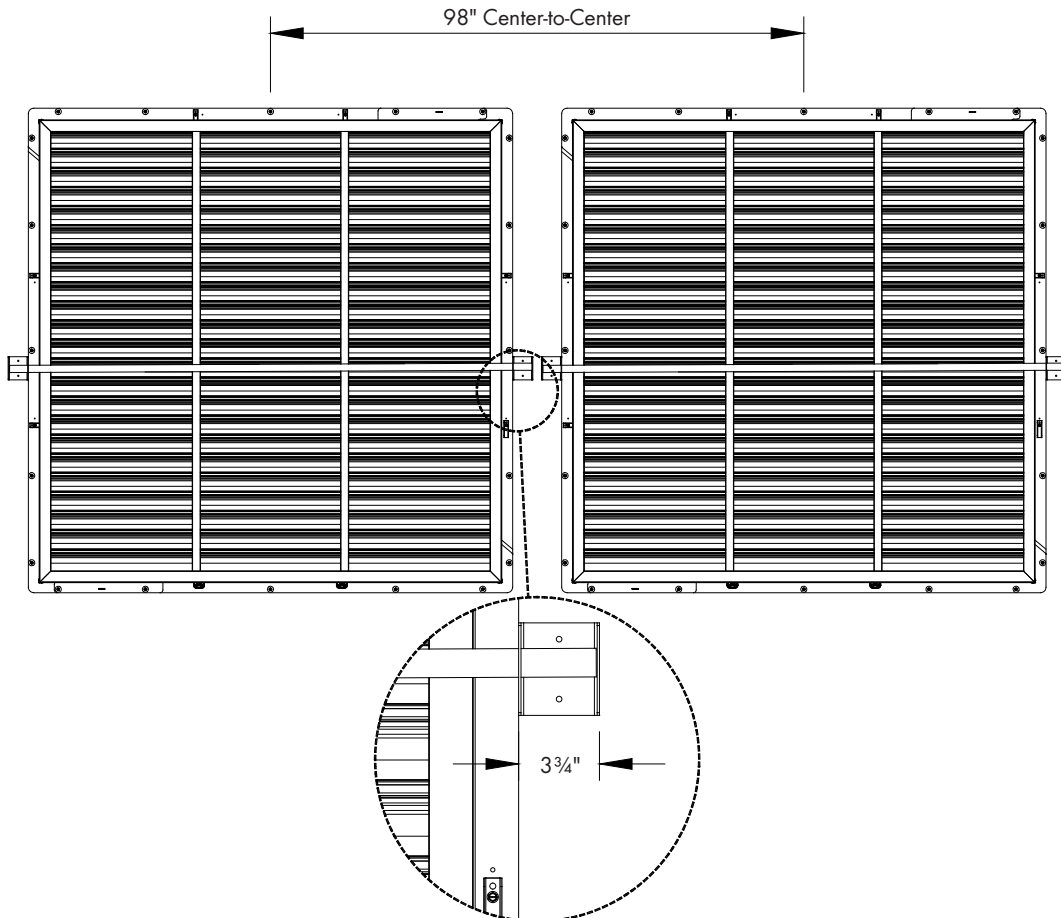

Elevation View
(Recommended Fan Spacing)

1.3B Minimum Fan Spacing (Optional)

If the fans are to be installed closer, then the Wind Kit Bracket for one fan should be offset 6" up or down from the previous fan, then the minimum fan spacing is 93" Center-to-Center. *See Figure Below.*

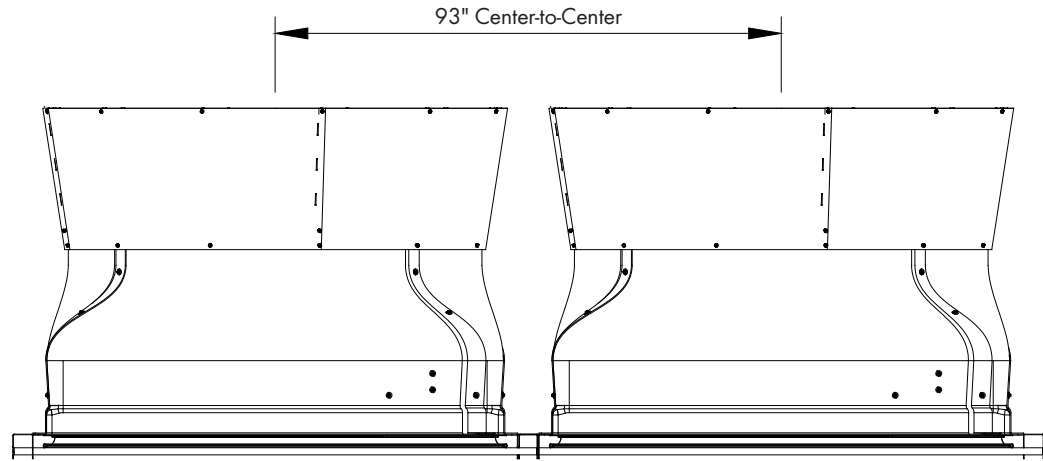

Top View

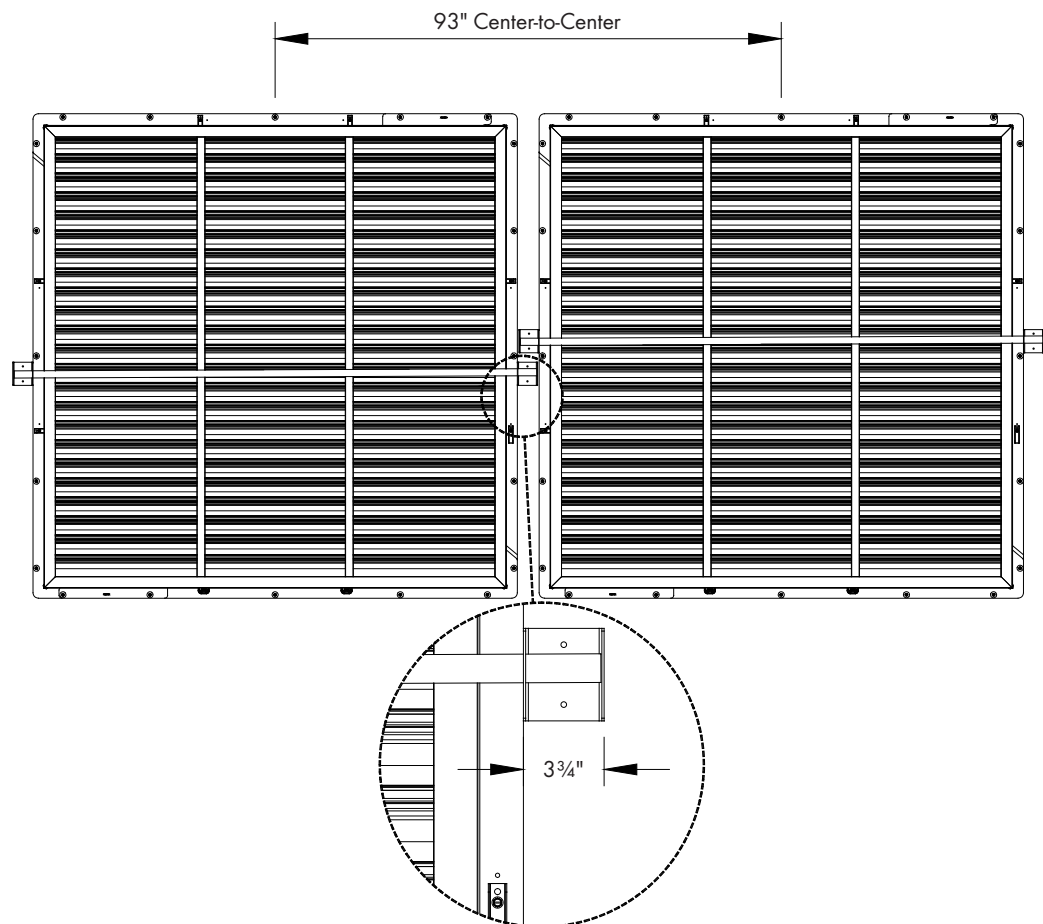

Elevation View

Installation Instructions

2.

2.1 Installation

Step 1

Construct the framed opening to correct size according to the Chart on Page 5. The frame should be constructed of 4x4 Treated Posts or double 2x Treated Studs. 2 fans can fit between Columns that are 20' O.C., and 3 fans can fit between Columns that are 25' or 30' O.C. See [Figure 1A](#), [1B](#) and [1C](#).

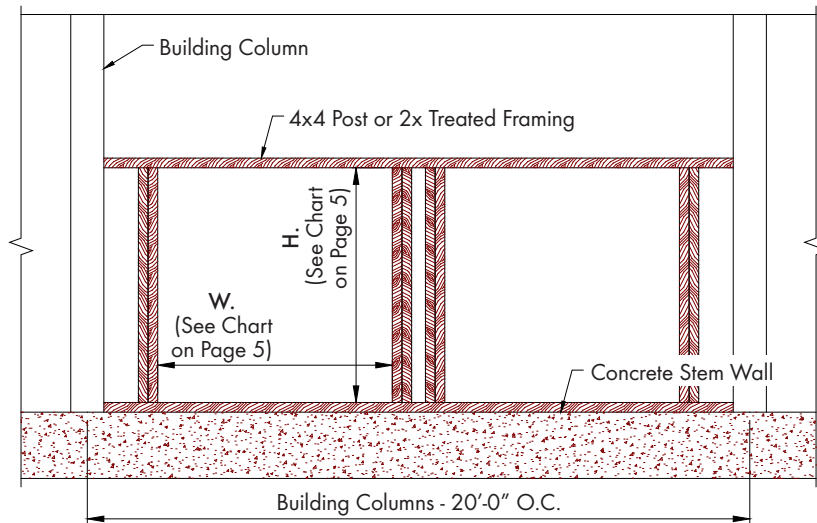

Figure 1A

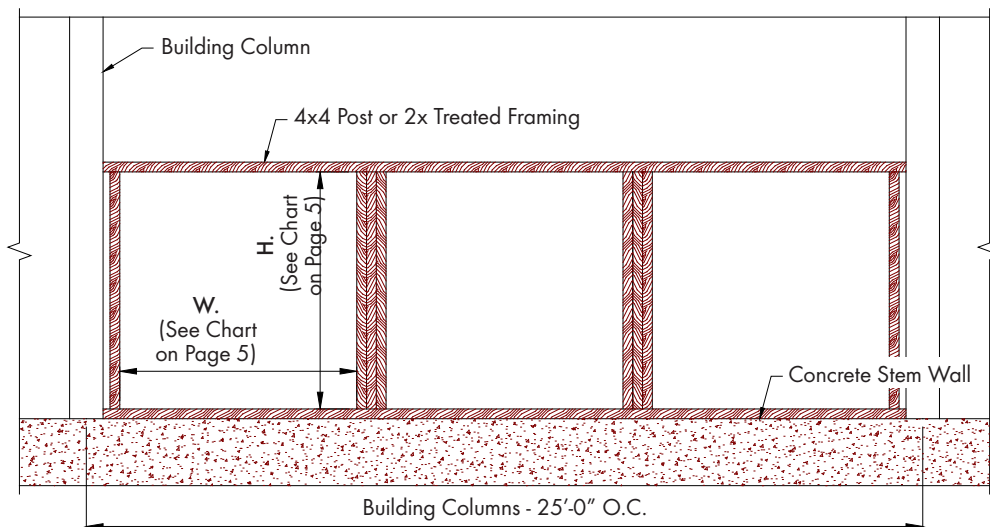

Figure 1B

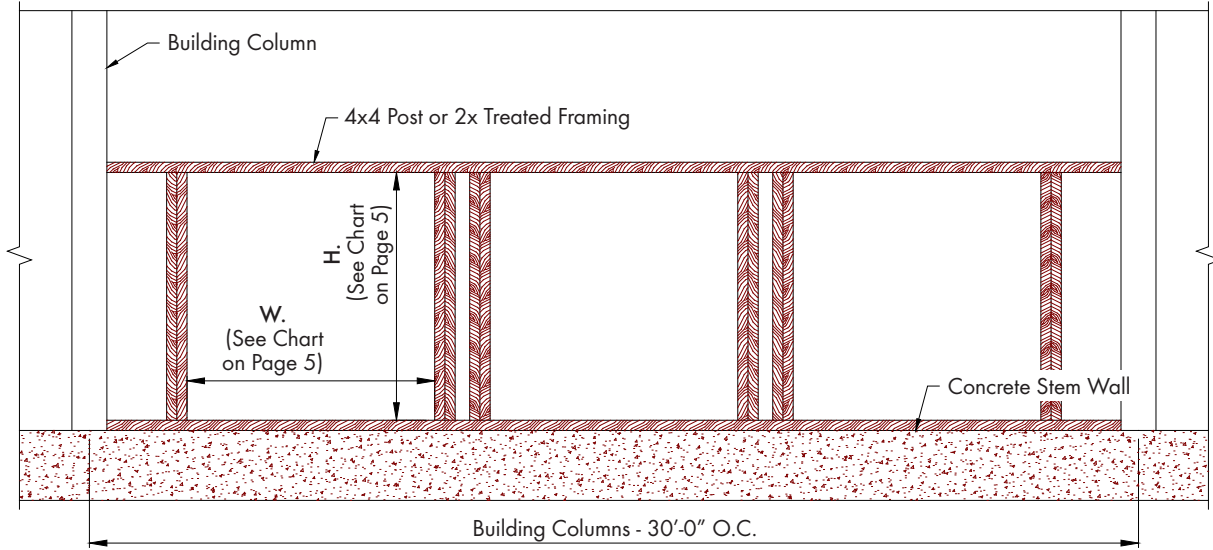

Figure 1C

WARNING:

A Munters Lift Kit, FH1890, is required for installation of Atlas Fan. One Lift Kit may be used for multiple Atlas Fans. Failure to use the Munters Lift Kit may result in damage to fan. **DO NOT** use chains to lift fan for installation. Damage from chains will not be covered under warranty.

Step 2

A Lift Bracket Kit is available to be able to lift fan into the framed opening. Attach each Lift Bracket to Bearing Bracket and Strut using (4) Bolts [F] and Nuts [G]. See Figure 2. Once fan has been installed in wall Lift Bracket can be removed and installed in next fan for installation.

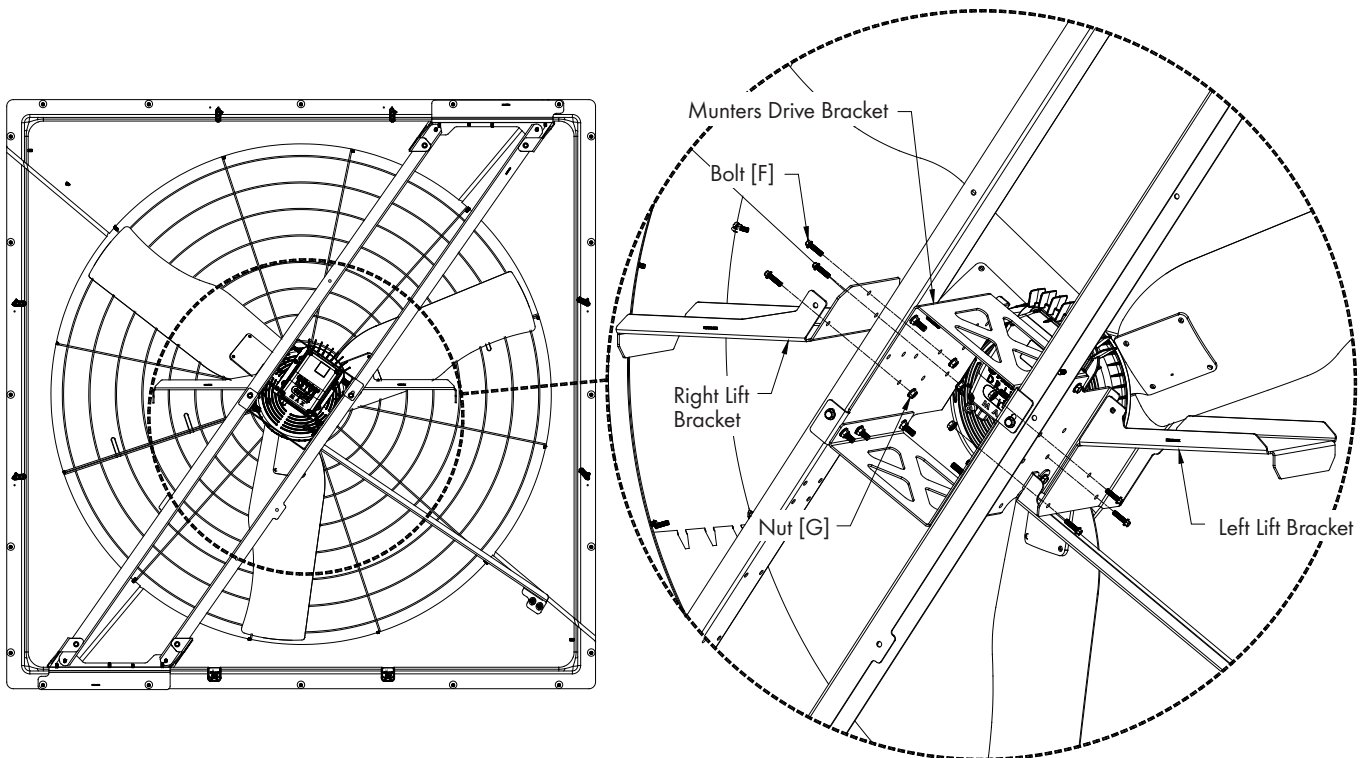
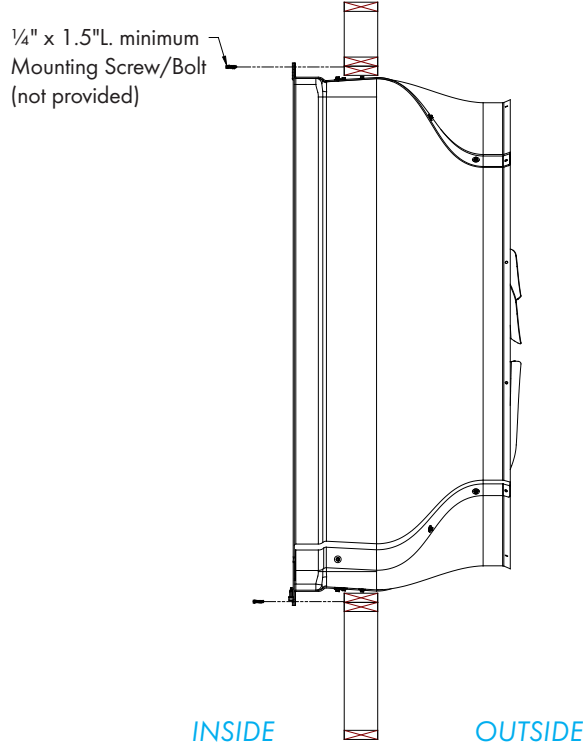

Figure 2
QM1495r6

Step 3A

Using Munters Lift Kit, FH1890, insert fan into the framed opening from the inside. While holding fan tight to framing, fasten top of fan with (5) 1/4" x 1.5"L. minimum Mounting Screw/Bolt (not provided). See Figure 3A. Next, fasten bottom of fan, then both sides with (5) 1/4" x 1.5"L. minimum Mounting Screw/Bolt (not provided) per side. Install flashing around opening tight to fan and caulk around fan to seal.



Note:
Once Fan is installed in wall, remove Lifting Brackets from Fan and install in next Fan for installation.

Figure 3A

Step 3B

If fan needs to be mounted, so that shutter does not stick into building then frame fan as shown in Figure 3B. Top and sides require 4" minimum and bottom requires 2" minimum.

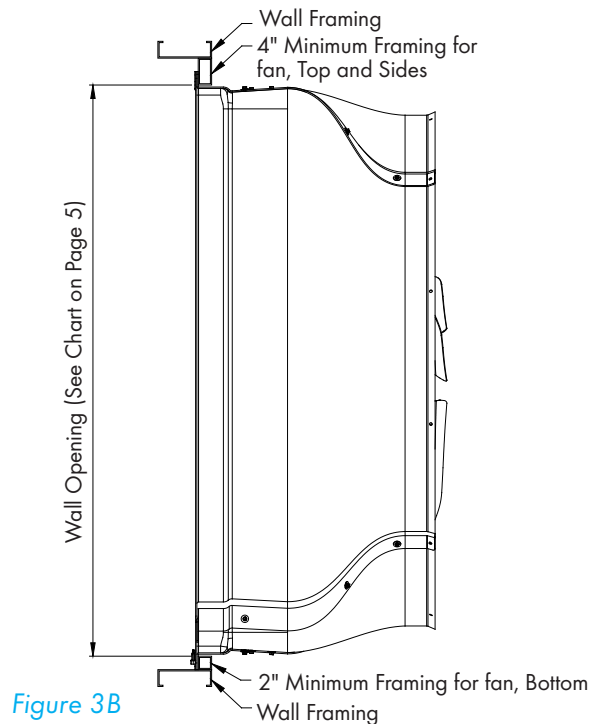

Note:
Once Fan is installed in wall, remove Lifting Brackets from Fan and install in next Fan for installation.

Figure 3B

QM1495r6

Step 4

Lay (4) Reinforcing Rings in a circular pattern on a flat surface with the tabs facing up. Fasten the Rings together at the End Flanges using (3) Bolts [D] and Nylock Nuts [E], leaving one pair of the End Flanges unattached. *See Figure 4.*

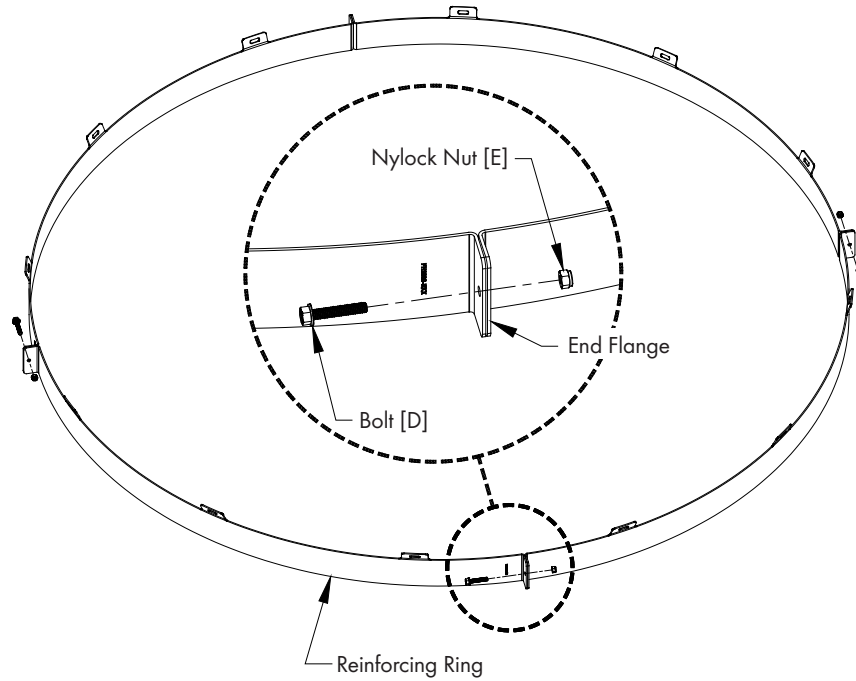

Figure 4

Step 5

Wrap the Reinforcing Rings around the outlet orifice of the fan and align the slots in the tabs with the holes in the orifice and secure the final End Flanges together using (1) Bolt [D] and Nylock Nut [E]. *See Figure 5.* Do not fully tighten the last bolt and nut at this time.

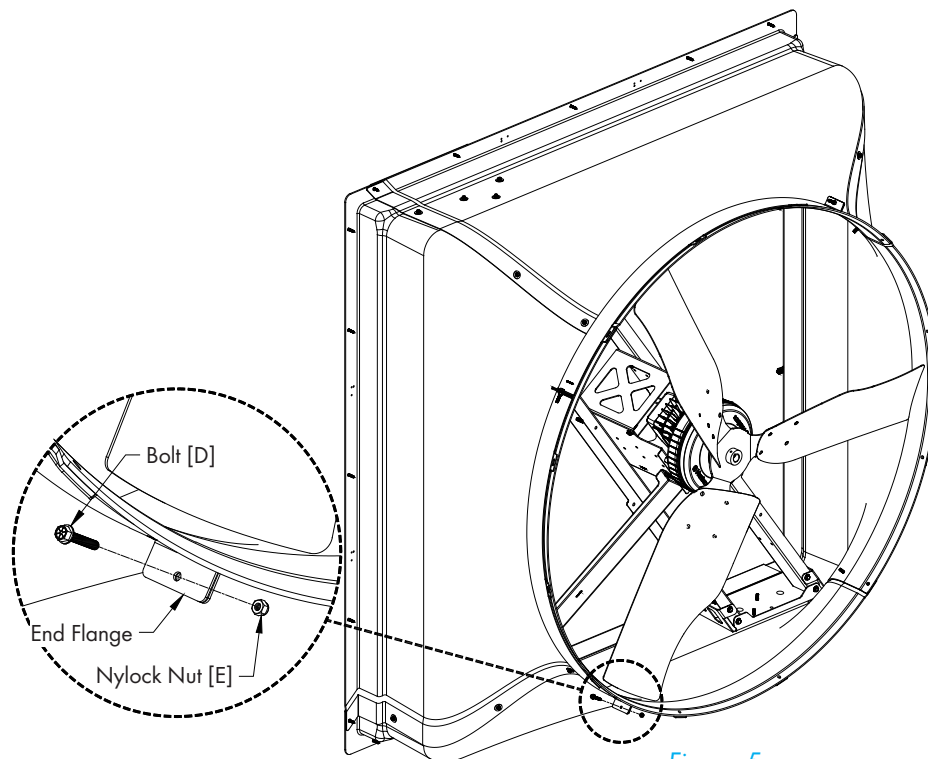

Figure 5

QM1495r6

2.2 Cone Installation

Step 6

Place all 4 cone sections on a flat surface with tabs from one facing slots of the next. See [Figure 6A](#). Curl up tab end of first cone section and insert tabs up into slots in the next cone section. A mallet may be needed to seat slots over tabs completely. See [Figure 6B](#). Repeat this step until all 4 cone sections are connected and laying flat.

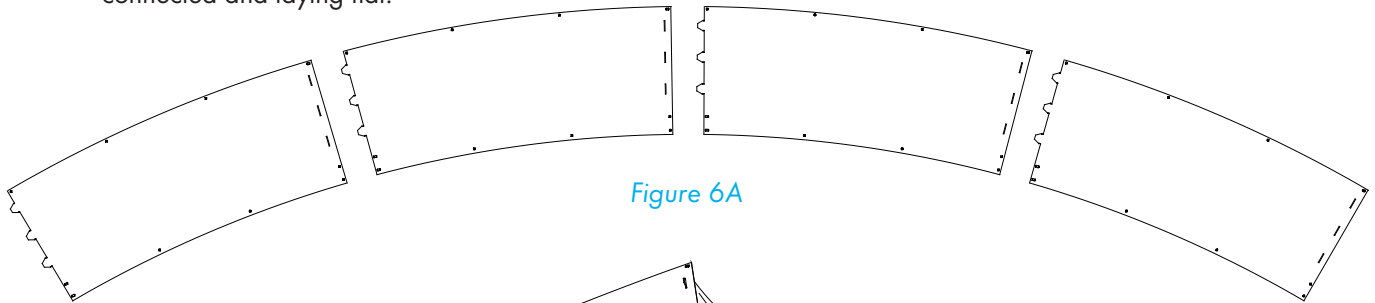

Figure 6A

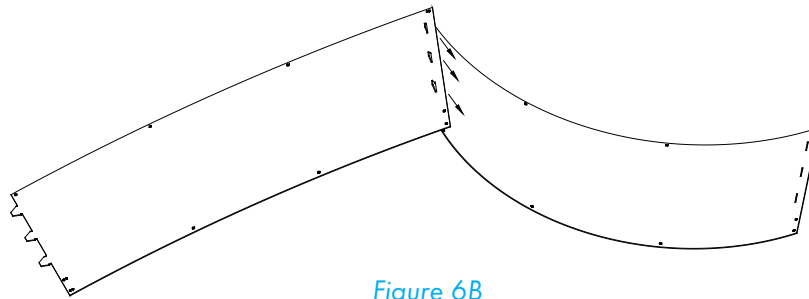

Figure 6B

Step 7

Fasten each of the joints in the single outer hole using (1) Bolt [A] and Nut [B], with the nut on the side with the tabs. At the inner pair of holes of each joint fasten using (1) Bolt [A] and Nut [B] with the bolt head on the side with the tabs. See [Figure 7](#).

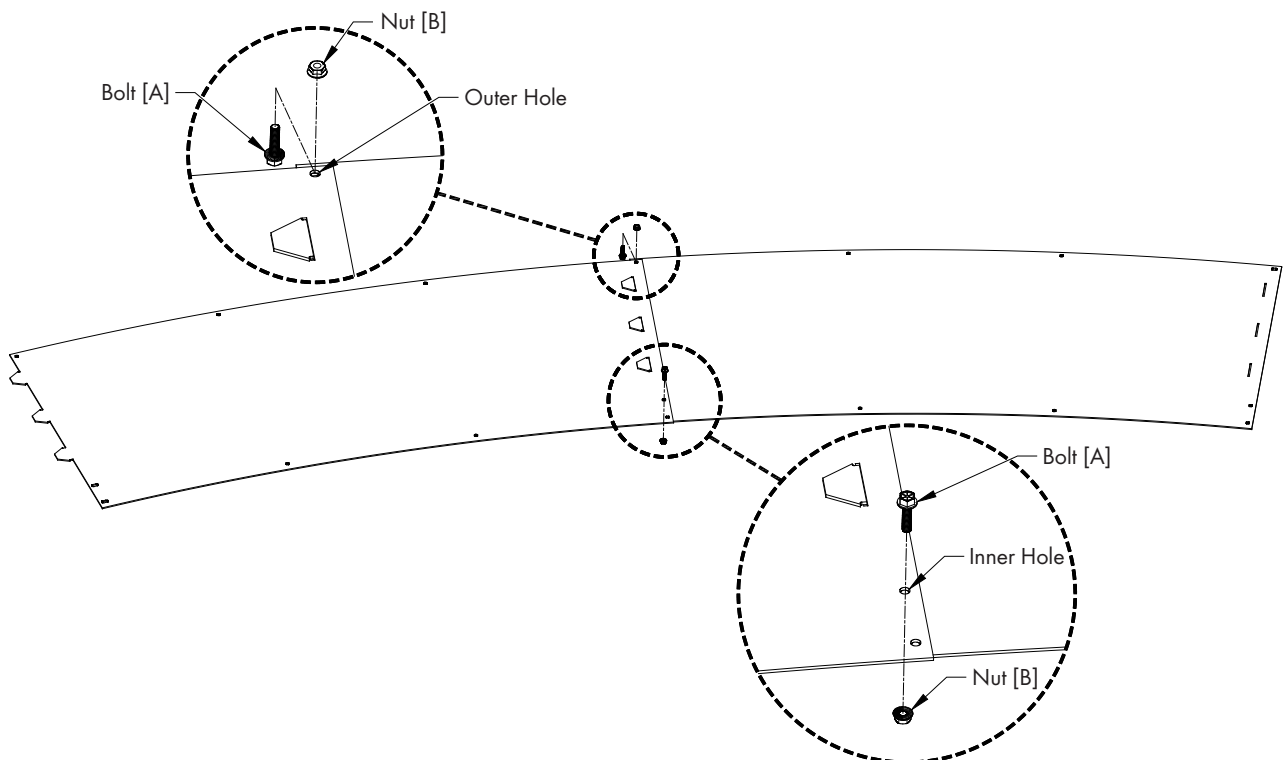

Figure 7

QM1495r6

Step 8

Stand cone sections on end and curl ends around to form cone so that the nuts are outside and tabs on inside. Insert remaining tabs into slots so tabs are inside cone and fasten final joint using (1) Bolt [A] and Nut [B], with nut on inside of cone. At the inner pair of holes fasten using (1) Bolt [A] and Nut [B] with bolt head on inside of cone. See Figure 8. Leave all bolts and nuts loose at this time.

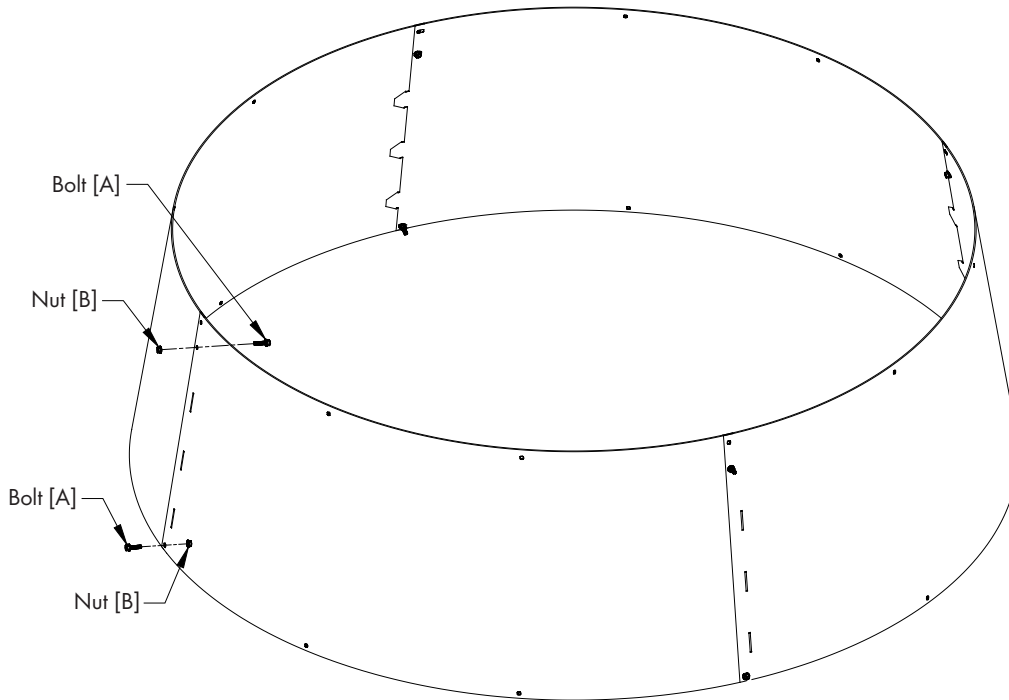

Figure 8

Step 9

Make sure the slots in the tabs of the Reinforcing Ring still line up with holes in the orifice of the fan. Install cone onto fan over the tabs of the Reinforcing Ring by putting cone over fan orifice and line up outer holes of cone with holes in fan orifice and tab slots. Fasten cone to fan orifice using (12) Bolt [A], Washer [C] and Nut [B] with bolt and washer on inside of fan orifice and nut on outside of cone with the tabs between orifice and cone. See Figure 9. Torque the last Ring Bolt to 125 in-lbs [14 Nm], and then tighten all the cone bolts at this time.

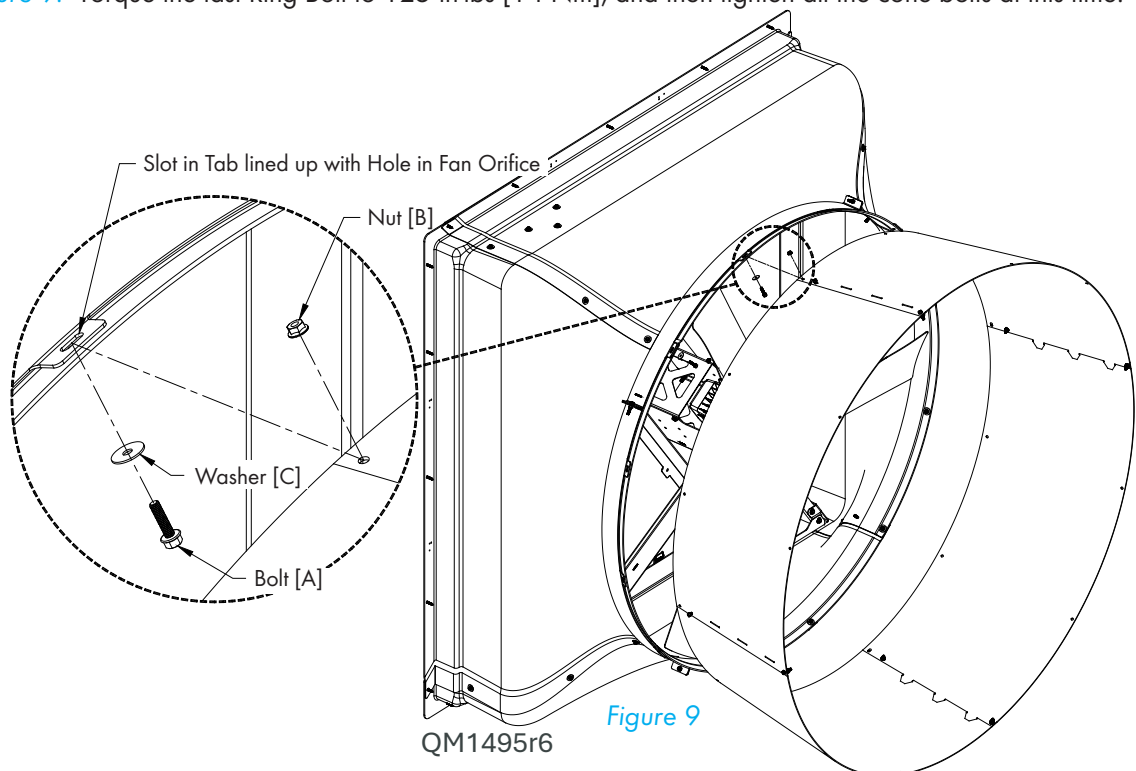

Figure 9

QM1495r6

Step 10

Find the 2 Guard Sections and line the 2 of them up with the eyelets both facing the same direction. Then secure the guard sections together by wrapping the wire loop on each guard section around center wire of opposite guard section. See Figure 10.

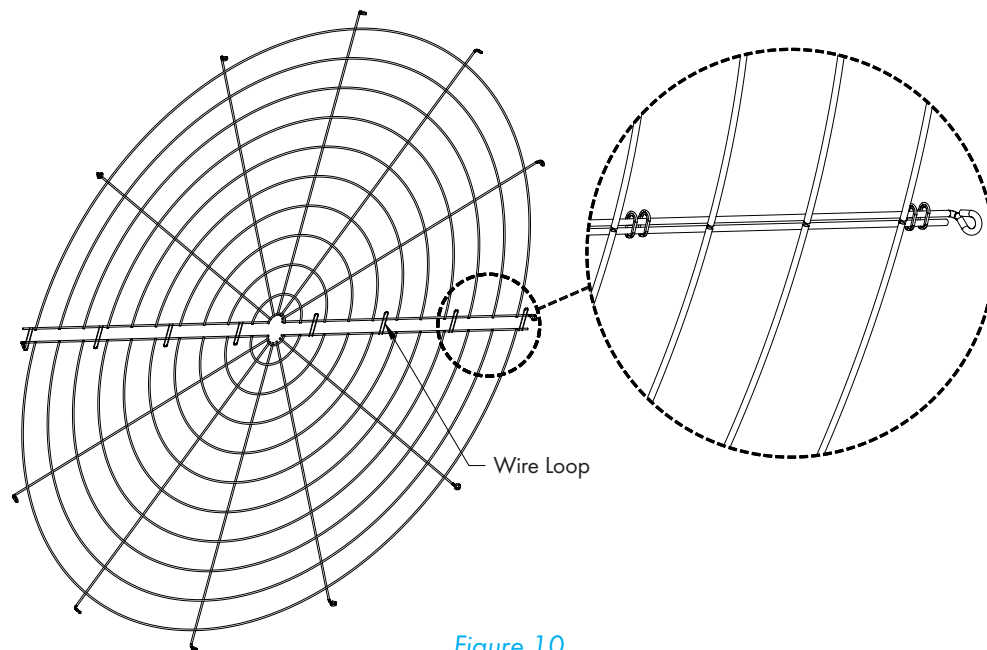

Figure 10

Step 11

Insert guard into cone with the eyelets facing you. Install eyelets over (4) Bolts already installed at joints in cone and fasten with Nut [B]. Secure (8) remaining eyelets using Bolt [A] and Nut [B]. See Figure 11.

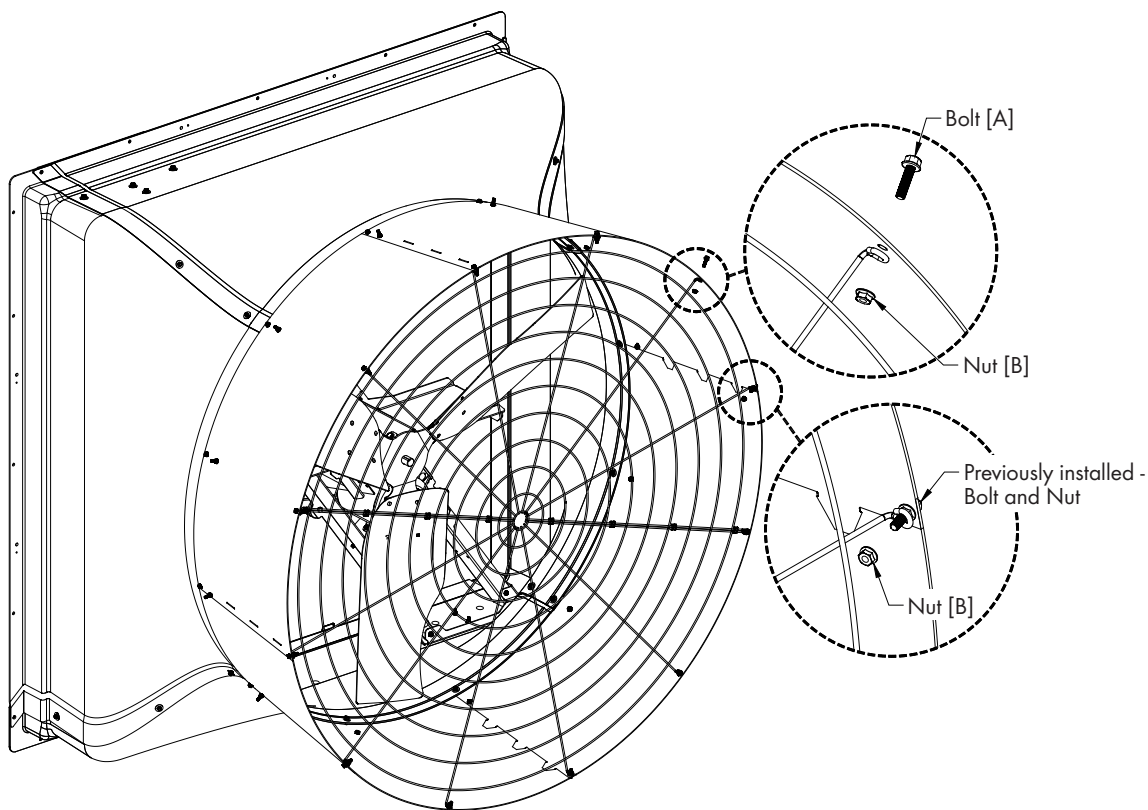

Figure 11

QM1495r6

2.3 PT Shutter Installation

Step 12

Install (6) End Pivoting Shutter Clips [K] at the pre-drilled shutter clip holes in the flange using (1) Lag Screw [H] and Washer [J]. The Washer should be mounted between the Shutter Clip and the flange. *See Figure 12.*

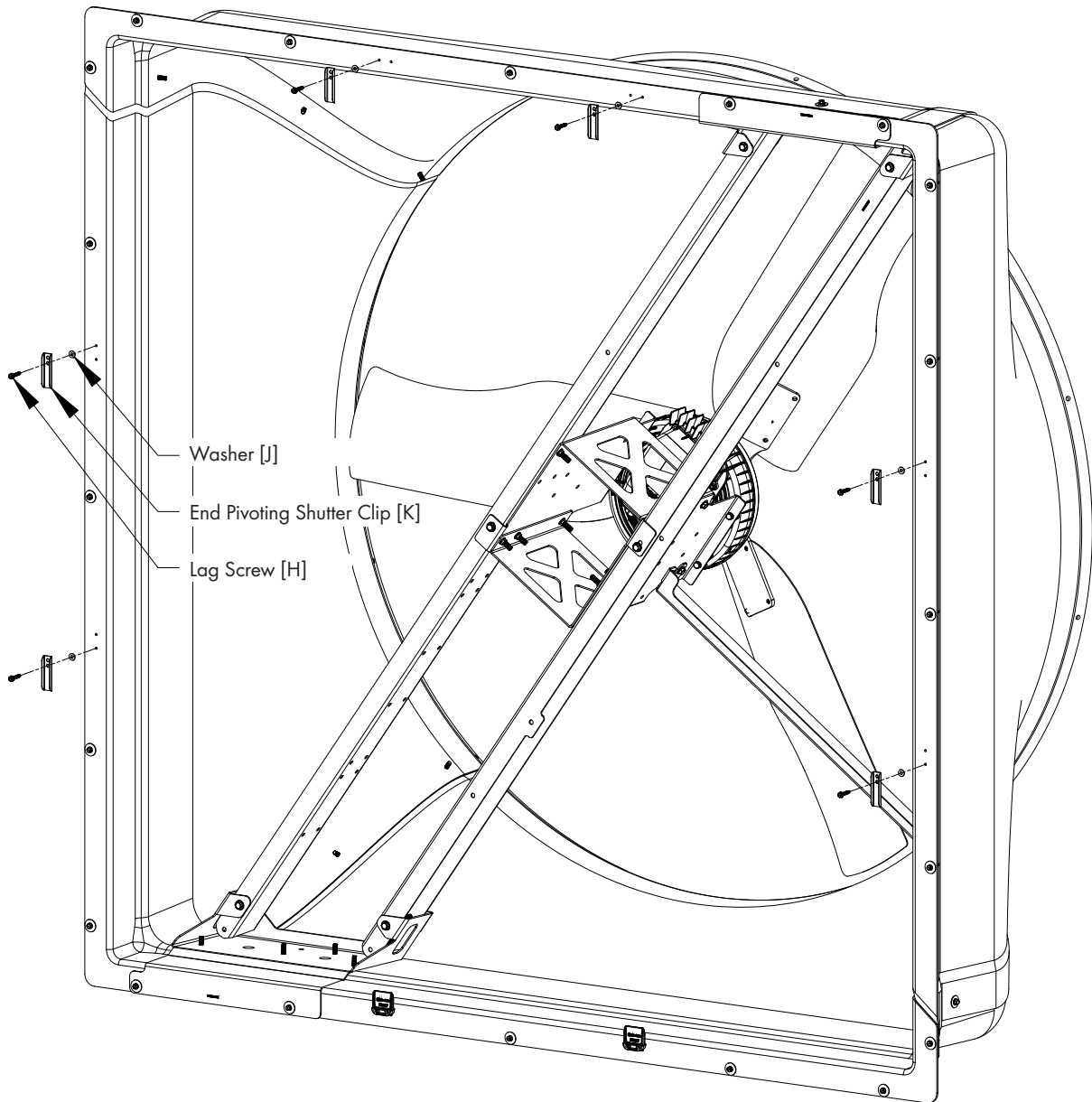

Figure 12

Step 13A

Insert PT Shutter into fan by sliding the bottom flange of shutter into bottom shutter clips and pressing shutter inward. See Figure 13A.

Note:

PT Shutter extends into room 2 5/16" from back of fan.

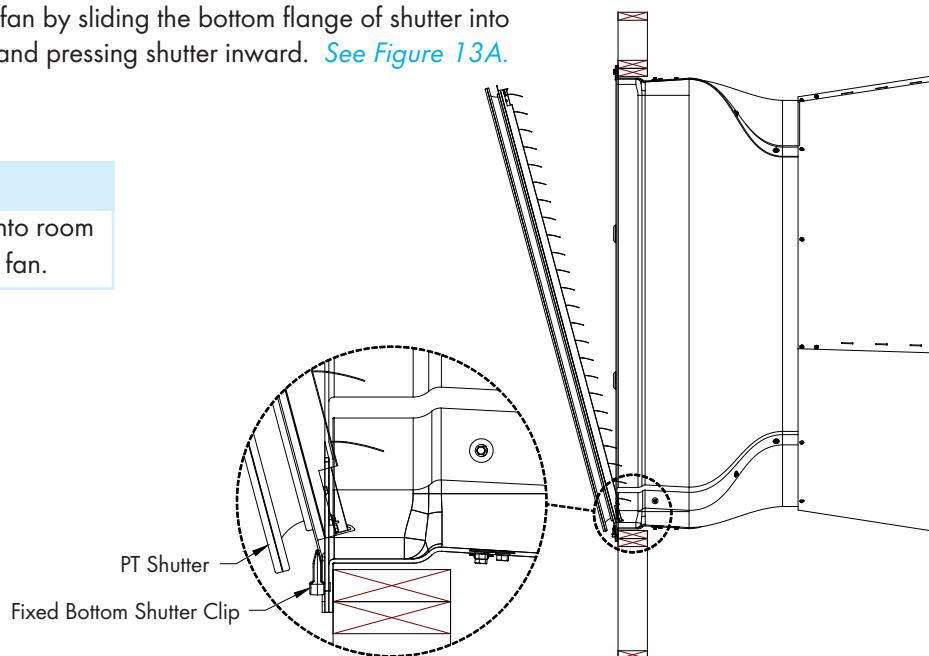

Figure 13A

Step 13B

Fasten shutter in place by rotating the side and top shutter clips over the shutter flanges. See Figure 13B.

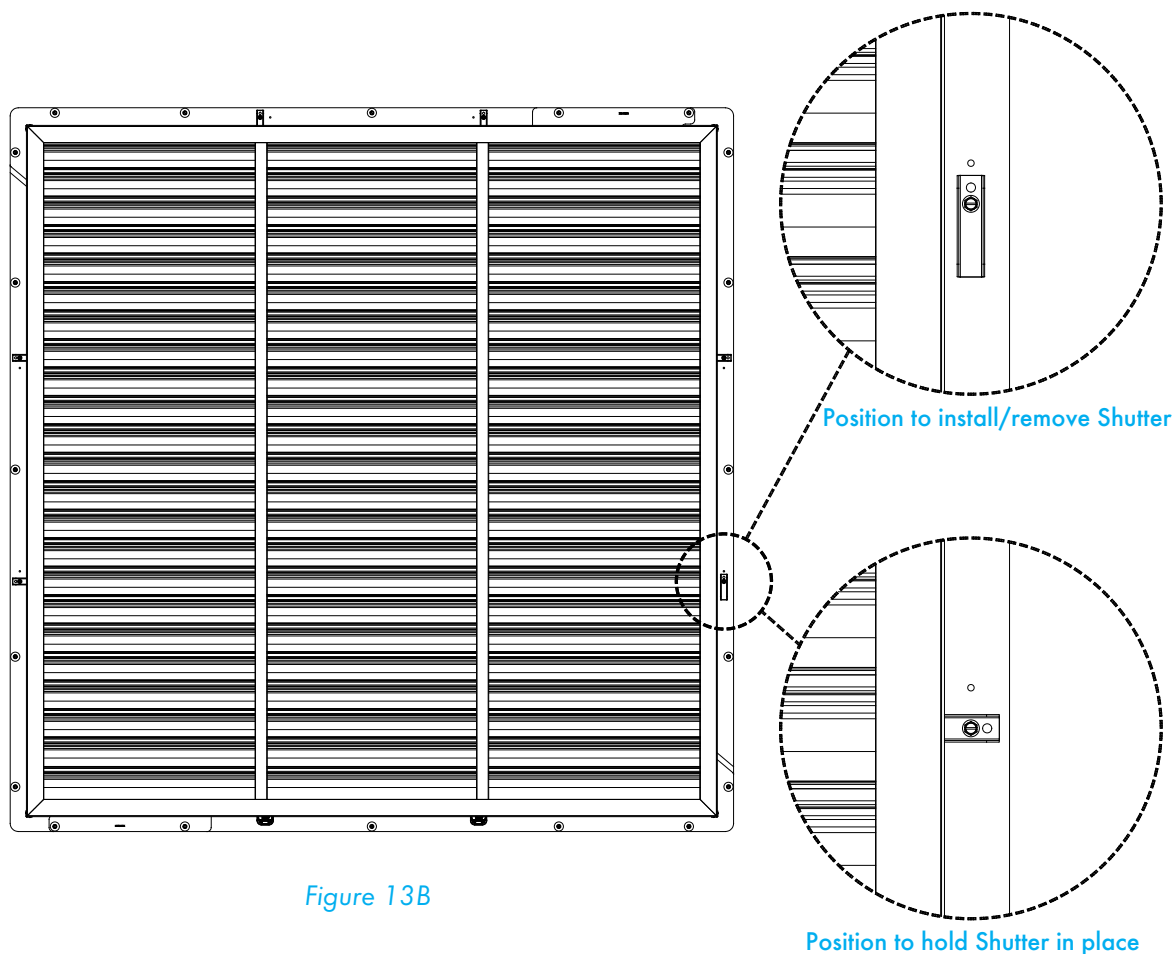

Figure 13B

2.4 Shutter Wind Kit Installation

Step 14

Mount one Wind Kit Bracket on each side of fan, 3'-3" above the bottom flange of fan. The opening in the 'U' slot should be facing up and each Bracket should be mounted in same direction. *See Figure 14A.* Fasten Brackets in place using (2) Lag Screws (not provided). *See Figure 14B.*

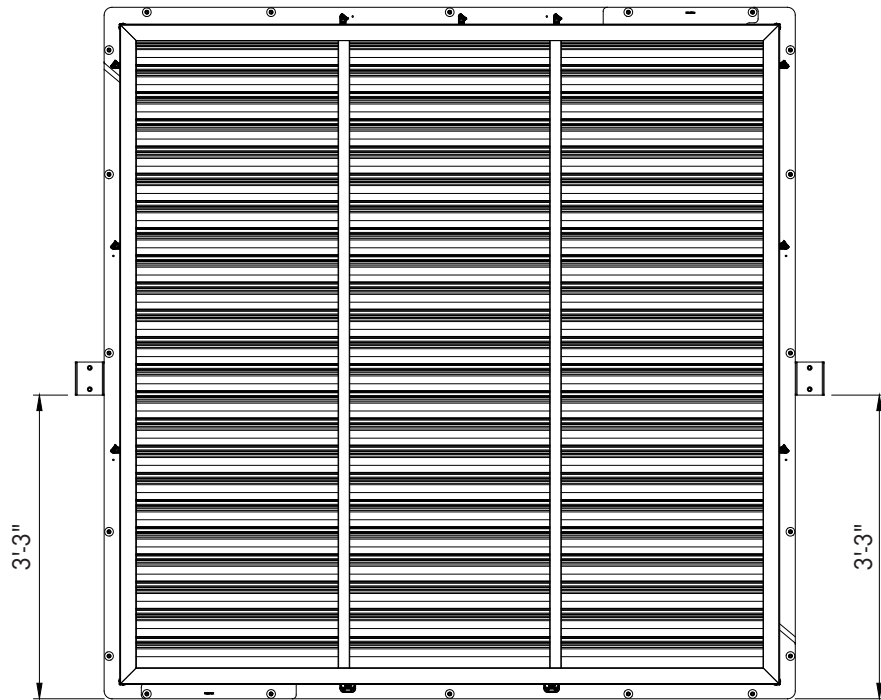

Figure 14A

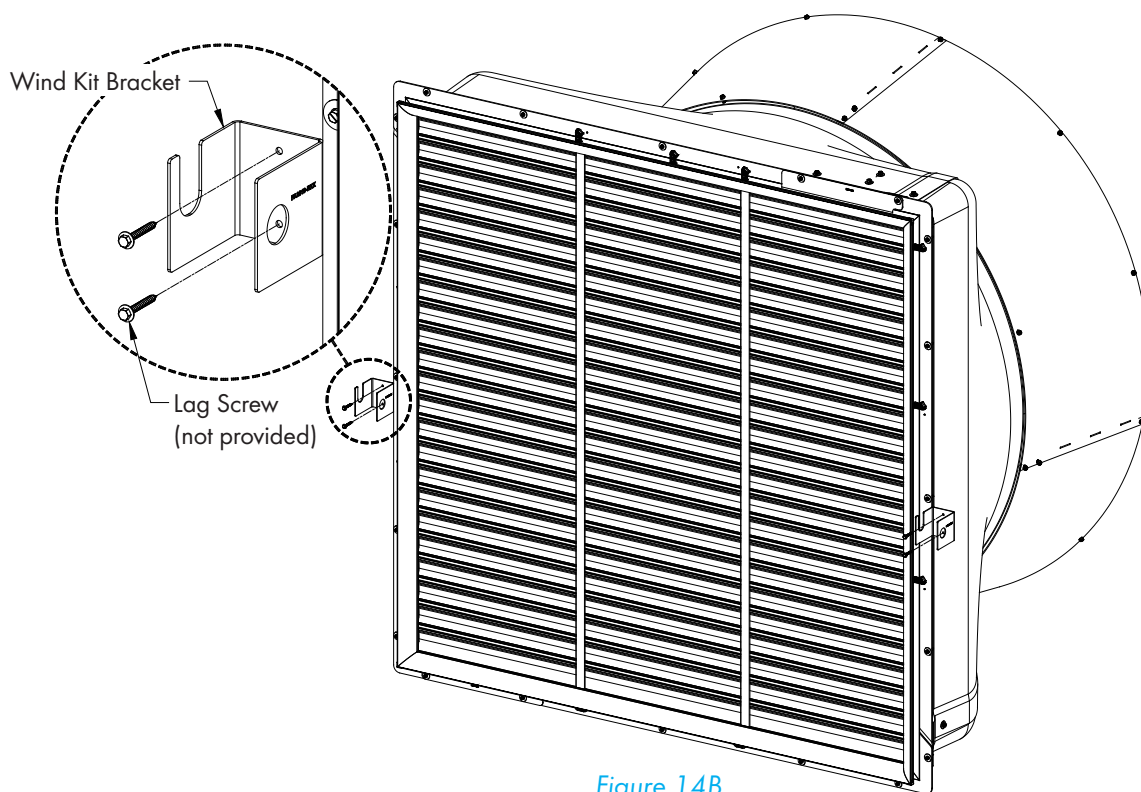

Figure 14B

QM1495r6

Step 15

Slide the Wind Kit Pipe into the hole in the Left Wind Kit Bracket until it stops at the other side of the Bracket and set Pipe down into slot in opposite Bracket. See Figure 15A. For the completed Wind Kit installation See Figure 15B.

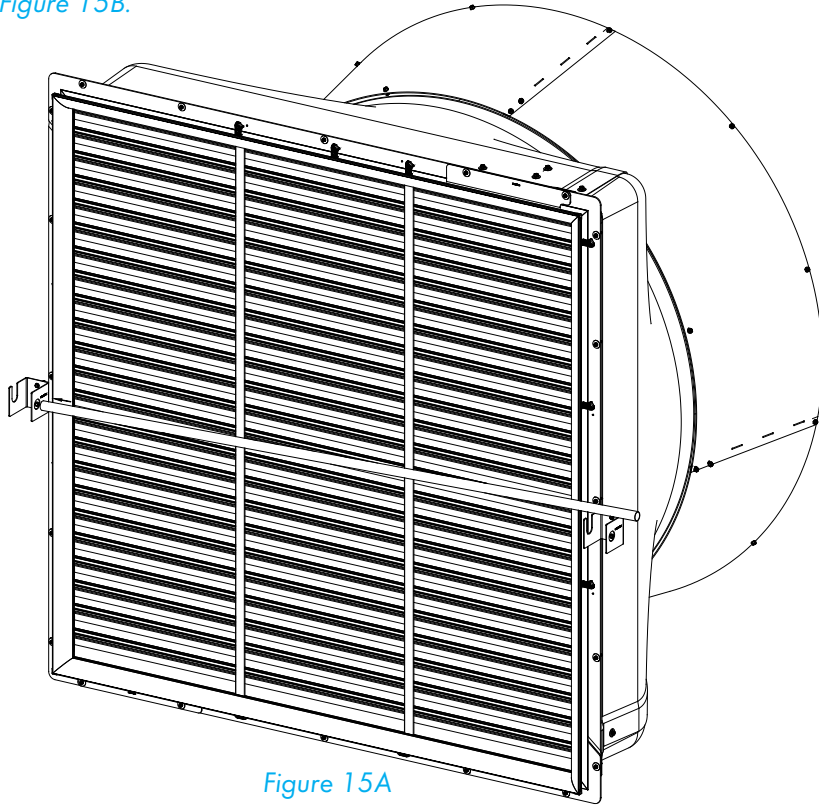

Figure 15A

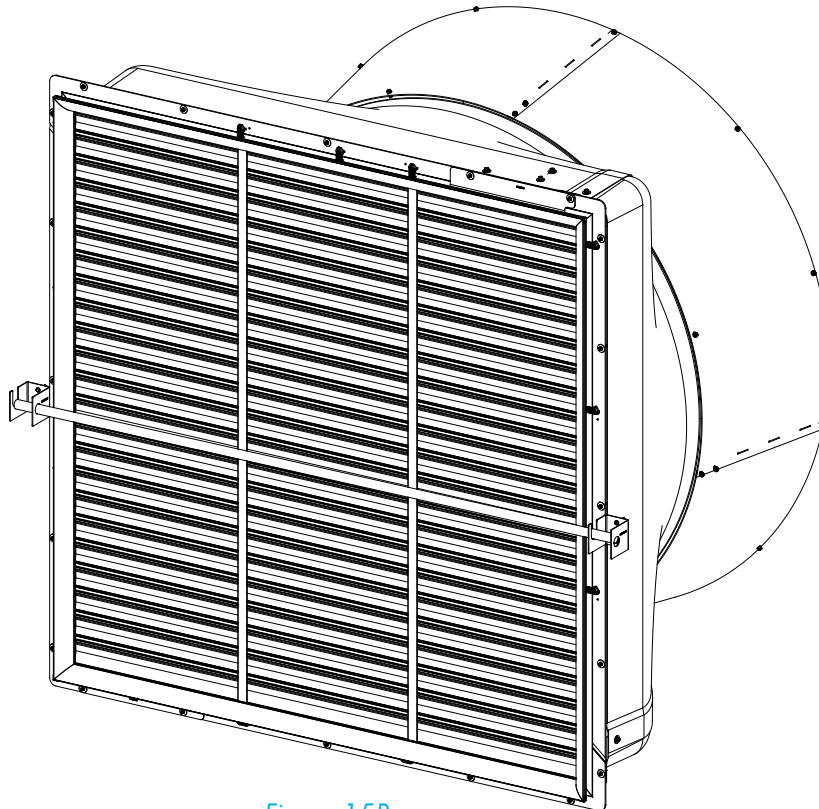

Figure 15B

QM1495r6



All wiring should be installed in accordance with National, State, and Local electrical codes. Fans used to ventilate livestock buildings or other rooms where continuous air movement is essential should be connected to individual electrical circuits, with a minimum of two circuits per room. For electrical connection requirements, refer to diagram on motor nameplate and to information enclosed with the Munters environmental control to be used. After wiring check for proper motor rotation.

Three Phase Fans: motor overload protection should be provided for each fan. A three-pole motor starter or slow blow motor fuses must be used. See Figure 16.

NOTE: A safety cut-off switch should be located adjacent to each fan.

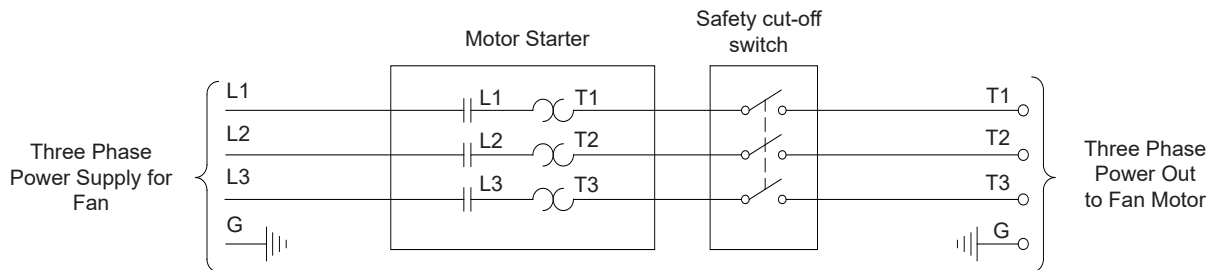

Figure 16

Three Phase - Motor Overload Protection with Disconnect

KEY:

- L1=Line 1
- L2=Line 2
- L3=Line 3
- G=Ground

3.1 Recommended Wire Routing:

As the power cable exits the Munters Drive Box form a drip loop and then run power cable down along strut and "Zip" tie the cable to strut to prevent cable from getting tangled in the propeller. See Figure 17. Then run the cable out of fan to circuit breaker or control panel. (Continued on next page).

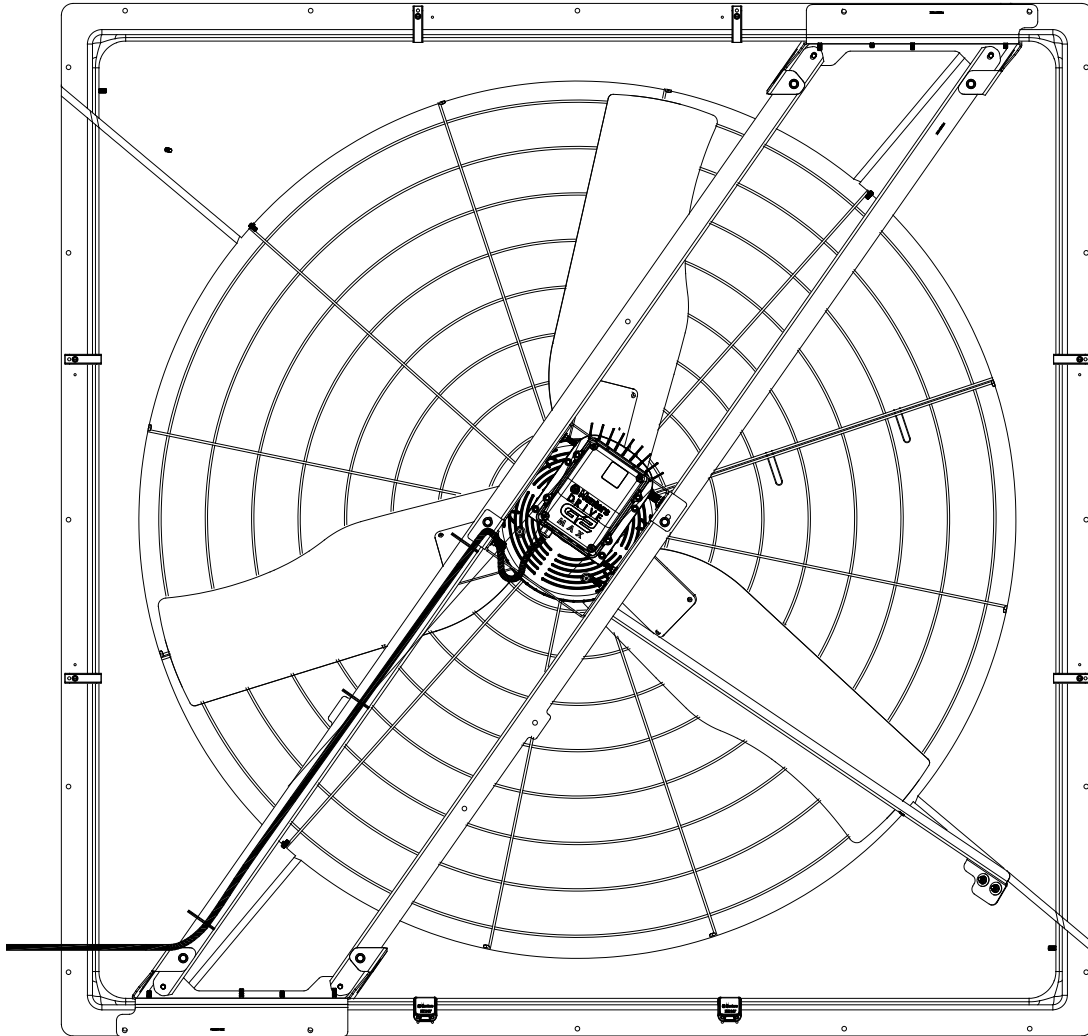
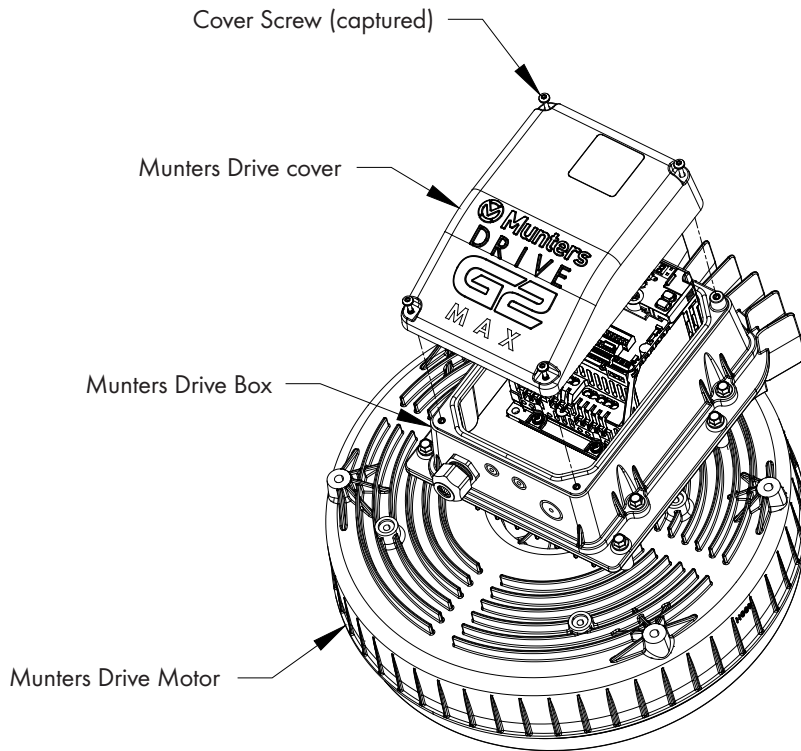

Figure 17

WARNING: Fan is designed to be operated with shutter in place. Do not apply power to fan without shutter being installed.

3.2 Three Phase Power connection:

All cables that enter the Munters Drive box must enter through a properly sized watertight fitting. Loosen the (4) screws in the cover of the Munters Drive box to access the terminals inside to connect power and other cables. *See Figure 18A.* Run the 3 phase power cable through watertight fitting into the Munters Drive box and connect to the terminals "R/L1, S/L2, T/L3" and Ground in the box. *See Figure 18B.* The Munters Drive is prewired to the Motor.



*****WARNING*****
 Only the Cover of the Blue Box is designed to be removed. It has captured screws that remain in the cover. The Base of Blue Box and Heat Sink **must not** be removed from back of motor. Removing Base or Heat Sink from motor will void the warranty. Any water or other damage to the controller will not be covered if the either is removed.

Figure 18A

******* NOTE *******
 Power to the Drive must be within -4%, +8% of nominal voltage.
Munters Recommended;
 Absolute Minimum Voltage = 440V
 Absolute Maximum Voltage = 500V
 Munters Recommends Line to Line Voltage Unbalance to be 1% or less per NEMA MG-1-1998. Absolute maximum unbalance is 1.5%.

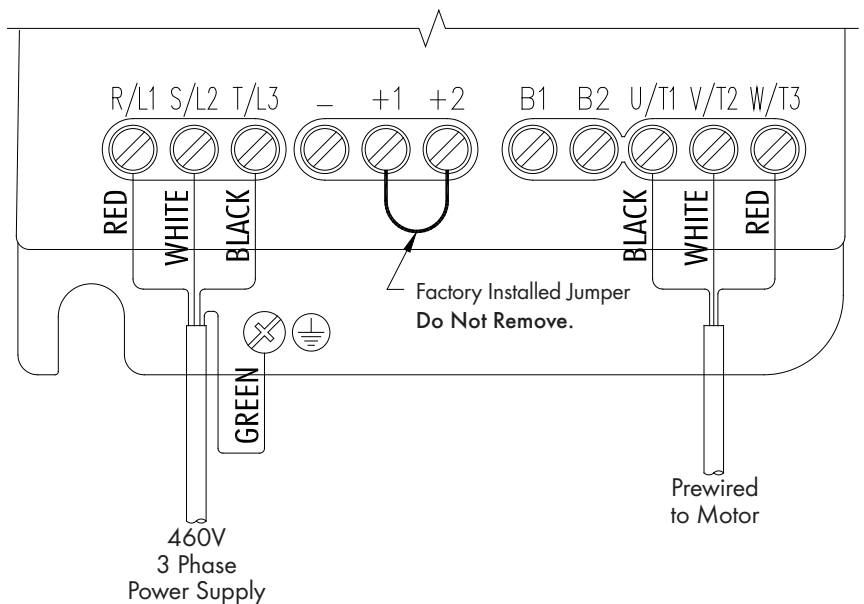

Figure 18B

3.3 Fan Operation with No Control

To operate the fan continuously with no control, provide a Jumper wires between terminals 'S1' and 'SN'. See *Figure 19*. Do not remove the Factory Installed Jumpers.

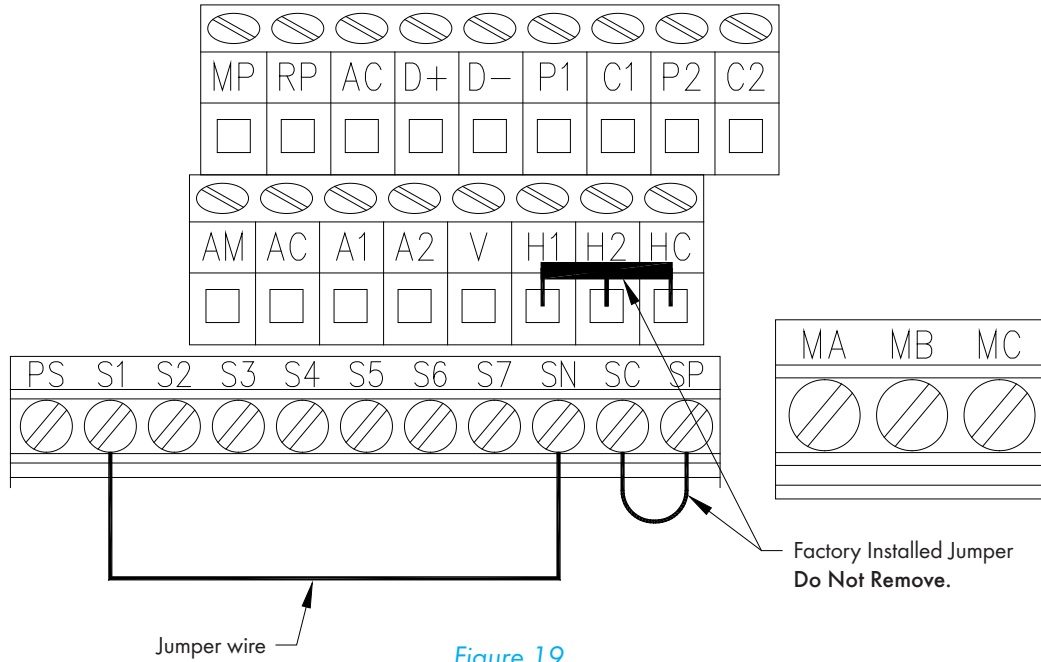

Figure 19

3.4 Fan Operation On/Off with Control

To operate the fan On/Off with a control, wire an 'ON' command from the 'SN' terminal to the input relay in the control and from the output of the control relay to the 'S1' terminal. See *Figure 20*. Do not remove the Factory Installed Jumpers.

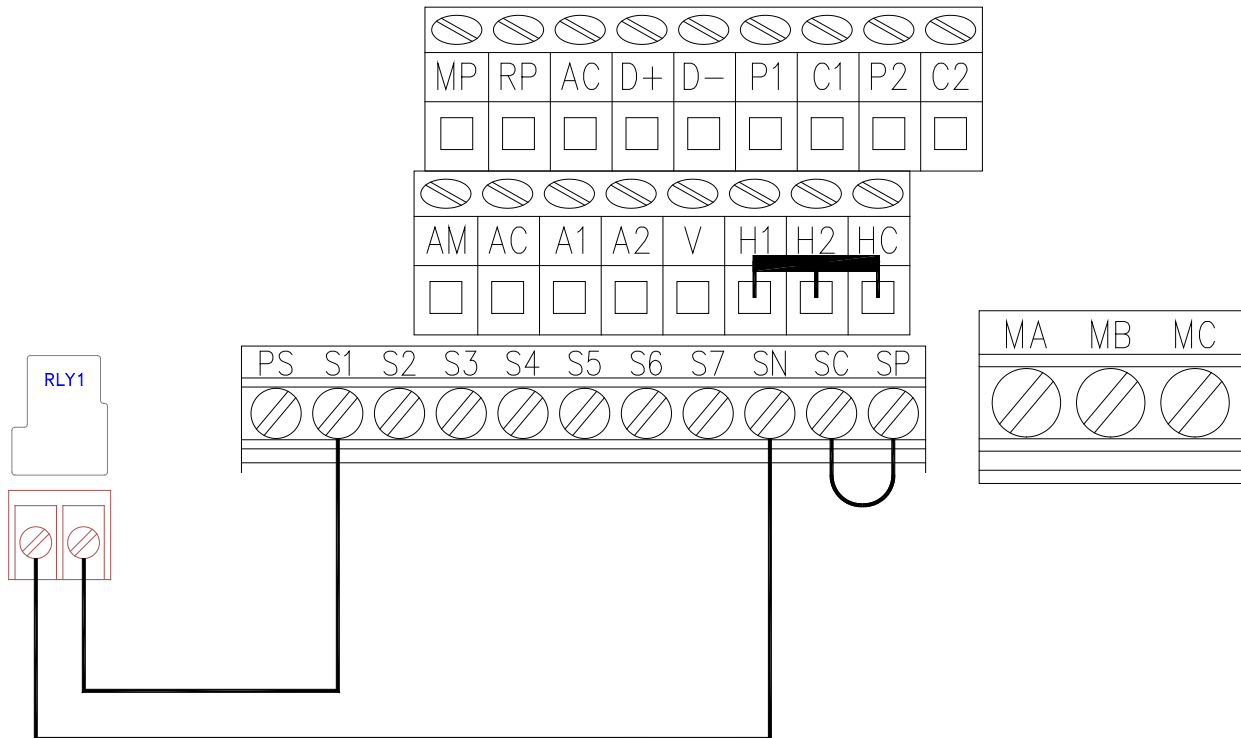

Figure 20

QM1495r6

3.5 Fan Operation Off/Low/High

To operate the fan Off/Low/High with a control, connect a wire from 'SN' terminal to the input side of the 'ON' relay in the control, then install a jumper from the input side of the 'ON' relay to the input side of the 'LOW' relay in the control. Then connect a wire from 'S1' terminal to the output side of the 'ON' relay and then connect a wire from the 'S7' terminal to the output side of the 'LOW' relay. See Figure 21. Do not remove the Factory Installed Jumper.

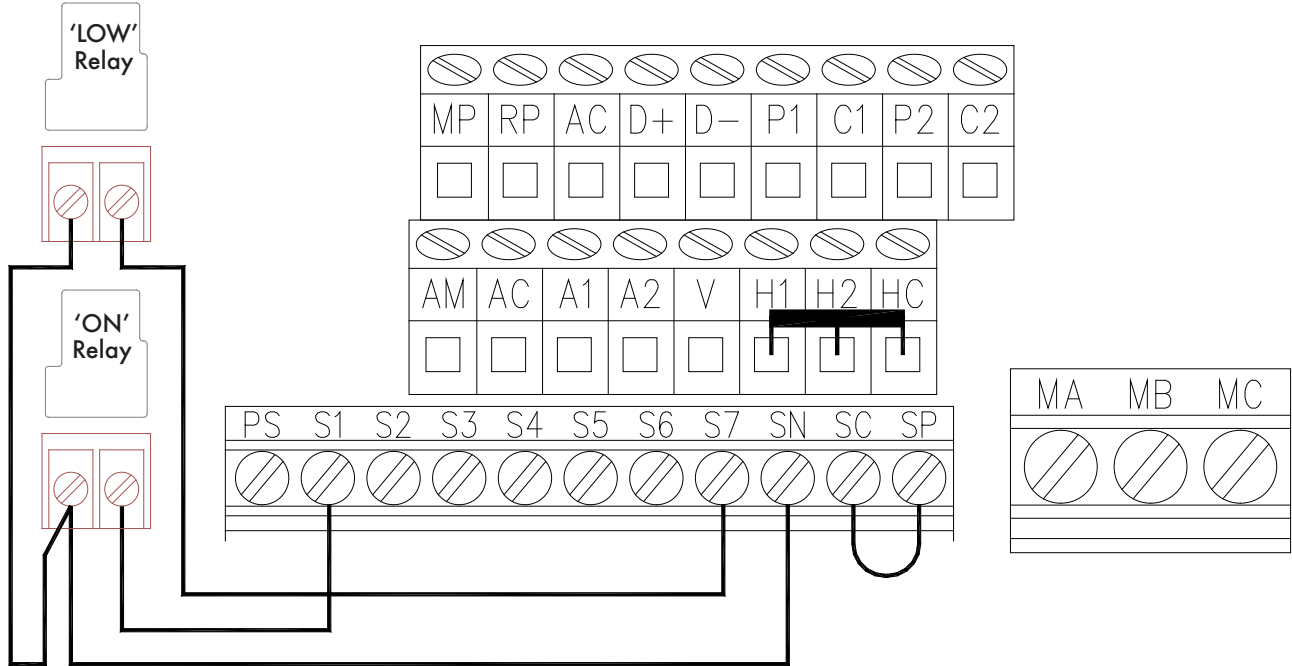
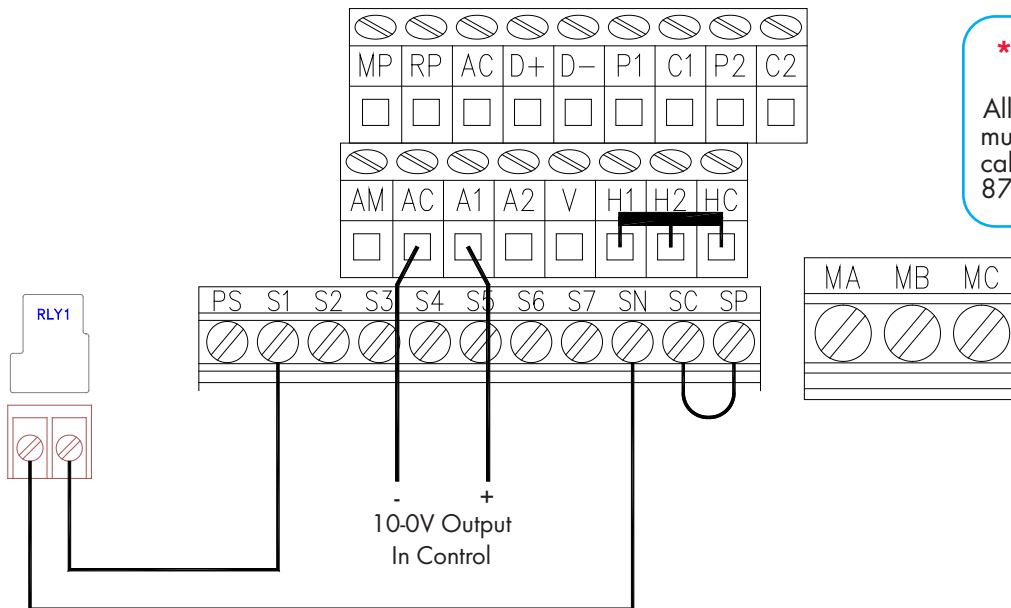

Figure 21

3.6 Fan Operation Off/Variable with 10-0V Signal

To operate the fan Off/Variable with a 10-0V Signal, wire an 'ON' command from the 'SN' terminal to the input relay in the control and from the output of the control relay to the 'S1' terminal. Then connect wires from the 10-0V output in the control to the 'A1' and 'AC' terminals in the Munters Drive Box. The '+' output in the control should go to 'A1' and the '-' output should go to 'AC'. See Figure 22. Do not remove the Factory Installed Jumpers.



***** NOTE *****
All Low Voltage wire must be shielded cable. i.e. Belden 8770 or equivalent.

Figure 22

QM1495r6

3.7 Fan Operation Off/Variable with Potentiometer

To operate the fan Off/Variable with a signal from a potentiometer, wire an 'ON' command from the 'S1' terminal to the input relay in the control and from the output of the control relay to the 'SN' terminal. Then connect wires from the Potentiometer as follows, connect '-' to 'AC', connect 'L' to 'A1' and connect '+' to 'V'. See Figure 23. Do not remove the Factory Installed Jumpers.

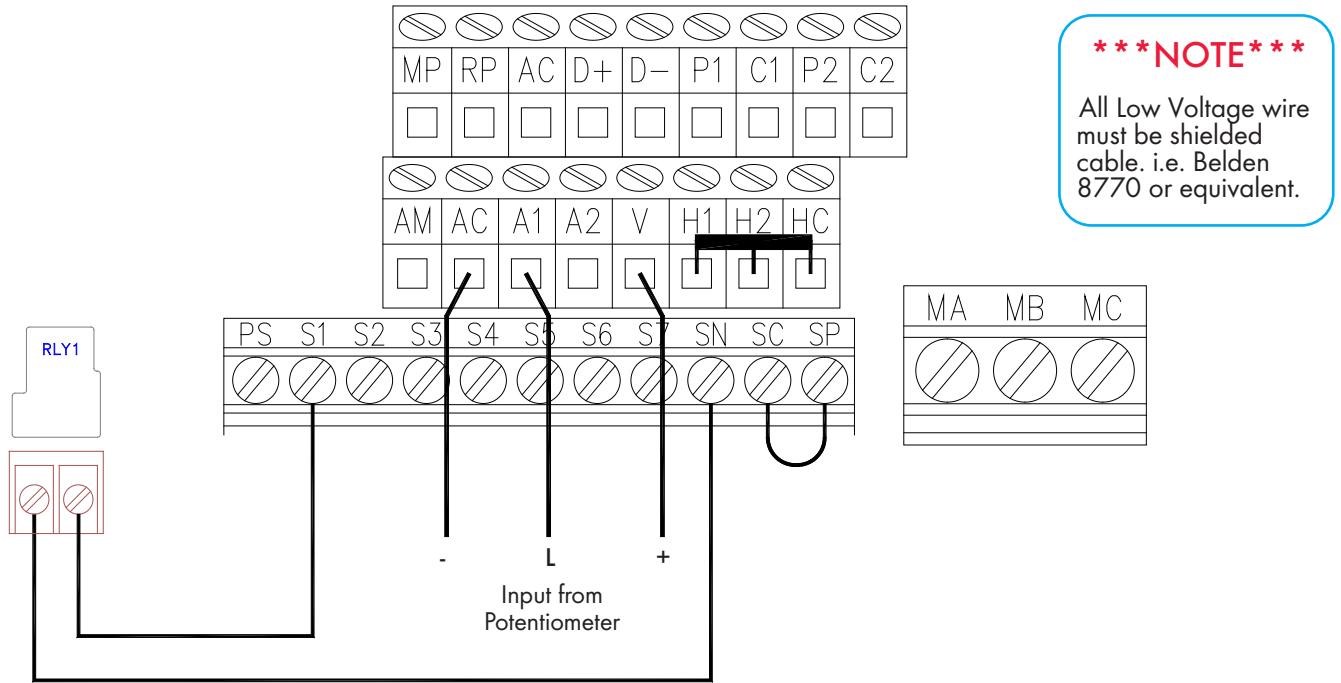

Figure 23

3.8 Alarm Connections

The Munters Drive uses a Normally Closed circuit for alarm connections. To connect a control to the Normally Closed output make appropriate connections from the control to 'MB' and 'MC' terminals. See Figure 24. Do not remove the Factory Installed Jumpers.

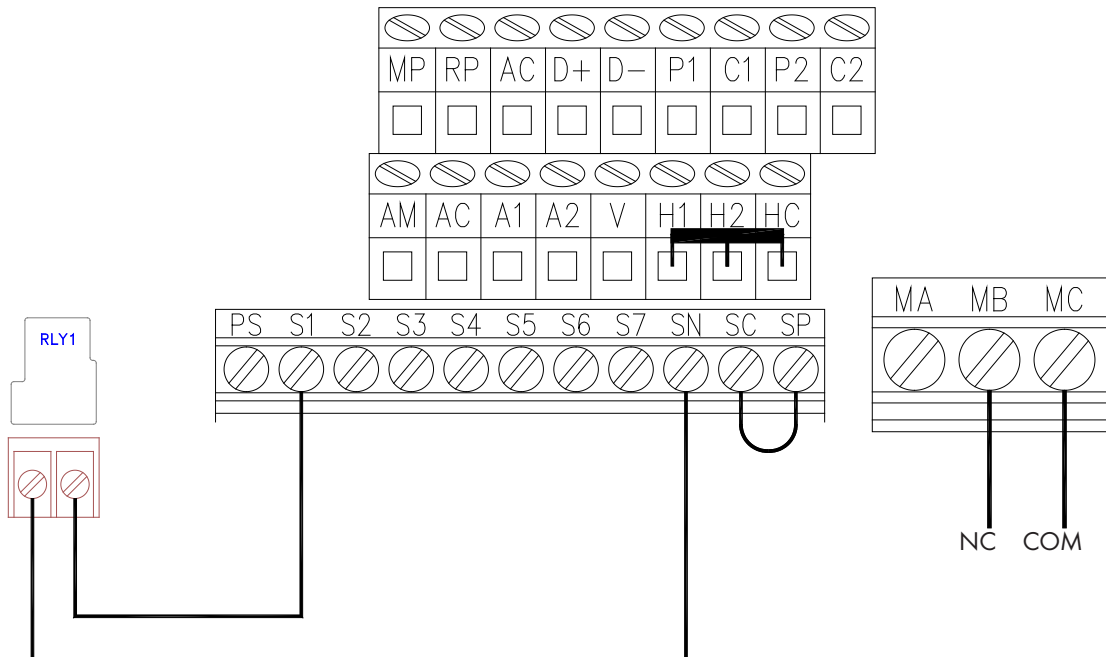

Figure 24

Operation and Maintenance

4.

4.1 Operation

INITIAL START-UP: With electrical power off, verify that the fan propeller turns freely and that all fasteners are secure. Turn on electrical power and confirm that the fan operates smoothly.

TEMPERATURE ADJUSTMENTS: Set the fan control to the temperature shown on your ventilations system drawing, or to a value which will provide the desired environmental conditions.



4.2 Maintenance

The following inspection and cleaning procedures should be performed monthly:

- 1) **INSPECT PROPELLER:** Check that propeller is secure on prop shaft or motor shaft and that there are no signs of damage. The blades are of a self-cleaning design and should not require maintenance.
- 2) **CLEAN** regularly for best results:
 - **FAN MOTOR:** Remove any dust accumulation from motor using a brush or cloth. (DO NOT use a pressure washer). A clean motor will run cooler and last longer. At the same time, verify that the motor is secure in its mount.
 - **SHUTTER:** Carefully clean dust from shutter blades and frame so that blades open and close freely. A brush or cloth should be used.
 - **GUARD:** Clean any dust or feathers from fan guards using a brush. Dirty guards can reduce airflow.
- 3) **CHECK FASTENERS:** For safety, all fasteners should be inspected 1 month after initial operation and yearly thereafter. Tighten any loose connections.
- 4) **INSPECT FAN CONTROL:** With power disconnected, inspect all electrical connections. Wiring should be secure and in good condition. Remove any dust build-up from control case and sensor using a soft brush or cloth.

NEVER CLEAN ELECTRICAL EQUIPMENT WITH A PRESSURE WASHER!

5.1 Troubleshooting



SYMPTOM	POSSIBLE CAUSES	CORRECTIVE ACTION
<ul style="list-style-type: none"> Fan Not Operating 	<ul style="list-style-type: none"> Fan control set above room temperature Blown Fuse or open circuit breaker Propeller blade contacting fan housing Fan control defective (i.e. Farm Premium, etc.) 	<ul style="list-style-type: none"> Set to a lower temperature Replace fuse or reset breaker Realign motor in fan housing Repair or replace control
<ul style="list-style-type: none"> Fan Does Not Start Caution: There is a 10 second delay for the fan to start when an 'On' command is present. 	<ul style="list-style-type: none"> Munters Drive motor/controller issue 	<ol style="list-style-type: none"> Verify AC voltage is present at fan. Turn AC power off to fan for 1 minute Verify Prop turns freely <ol style="list-style-type: none"> If not contact Munters Product Support If it turns freely go to next step Turn AC power back on to fan <ol style="list-style-type: none"> If starts up and runs, fan OK <ul style="list-style-type: none"> Periodically observe fan to verify it is still running If it continues to run, fan is OK If fan stops, look through clear window in drive cover to check what drive display reads. Contact Munters Product Support If fan tries to start but stops, look through clear window in drive cover to check what drive display reads. Contact Munters Product Support If fan doesn't try to start, verify 'On' command signal is present at circuit board. Also, slide the switch on the circuit board to the 'On' position.
<ul style="list-style-type: none"> Fan Operating - Insufficient Airflow 	<ul style="list-style-type: none"> Shutter or Damper door jammed Guard dirty/clogged 10-0V signal set incorrectly 	<ul style="list-style-type: none"> Clean shutter or damper door Clean guard Check and adjust 10-0V signal
<ul style="list-style-type: none"> Excessive Noise 	<ul style="list-style-type: none"> Propeller blade contacting fan housing 	<ul style="list-style-type: none"> Sand fan housing to remove high spot
<ul style="list-style-type: none"> Excessive Vibration 	<ul style="list-style-type: none"> Motor loose on mount Propeller damaged 	<ul style="list-style-type: none"> Tighten fasteners Replace propeller

6.1 Winterizing

In most climates, it is probable that the ventilation system will never need to operate at a total capacity during the colder winter months. Consequently, it is advisable to “winterize” those fans which will not be used in cold weather to avoid unnecessary heat loss and condensation.

To winterize, turn fan control “off”. Install the insulated closure panel over the fan intake. If you don’t have an insulated closure panel, a piece of rigid insulation material can be used. Remember the insulation panel must be removed before warmer weather returns.

NOTE: At least one single speed fan should be left uncovered and with power available to provide air movement in the event of variable speed control difficulties.

6.2 Winter Weather Protection

To prevent cone or fan damage from snow or ice sliding off building roof, weather protection must be provided. A weather shelter may be constructed to cover the entire fan, *See Figure 25*, or snow guards may be placed on the roof, *See Figure 26*.

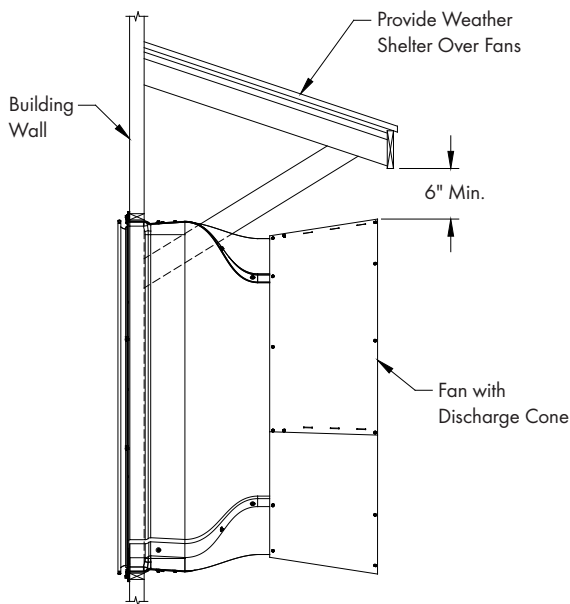

Figure 25

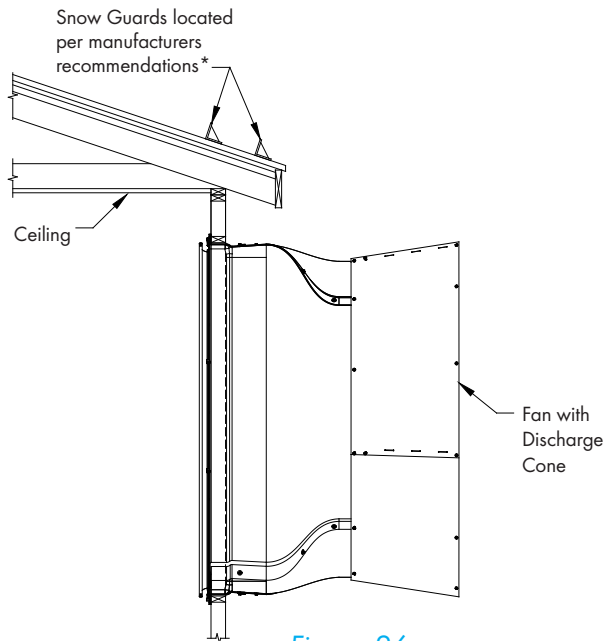

Figure 26

* Snow Guard Suppliers

Company Name	Phone No.	Fax No.	Web Site
Snojax, Inc.	800-766-5291	717-697-2452	www.snojax.com
Polar Blox	800-298-4328	814 629-9090	www.polarblox.com
LM Curbs	800-284-1412	903 759-3598	www.lmcurbs.com
Alpine Snow Guards	888-766-4273	888-766-9994	www.alpinesnowguards.com



IMPORTANT

Munters Product and System Warranties do not cover cone or fan damage from external sources.

Note: Snow guards are designed to prevent sudden, dangerous snow and ice slides when attached to the building roof according to manufacturers recommendations. The supplier listing above is given as a reference only. Munters does not endorse any specific snow guard product and no performance warranty is implied.

Exploded View

7.

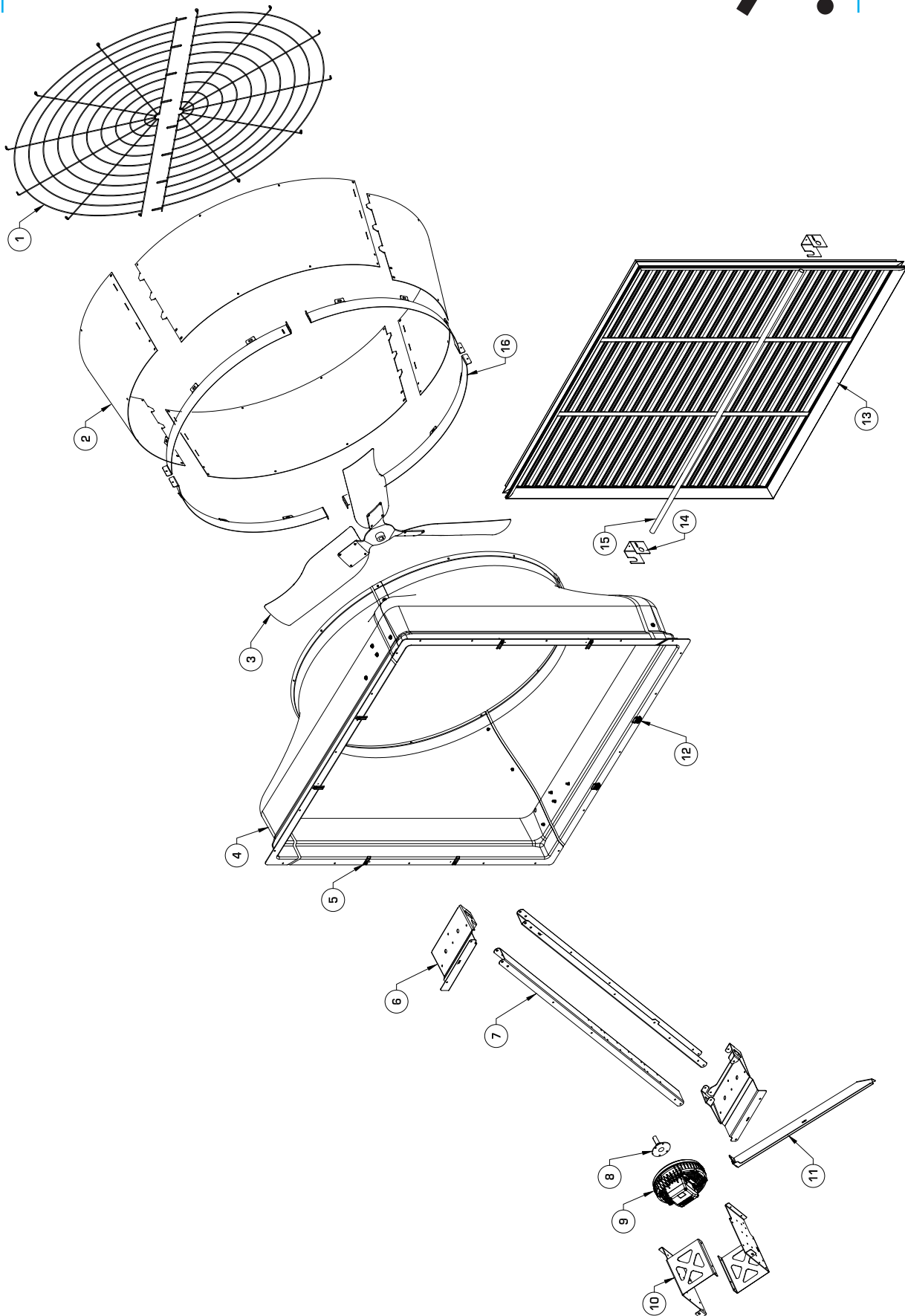

QM1495r6

Item	Catalog No.		Description	Qty.
	ATS74D3F43CT-HO	ATS74D3F43CT-HE		
1	FH1475	FH1475	Outlet Guard Kit w/HDW, ½ Round (2), 74" Fan, CTD BLK	1
2	FH4674	FH4674	Discharge Cone Section w/ Tabs, PL	4
3	FP1874	FP1874	Prop Assembly, 74" Fan, 3-Blade, GZ	1
4	FH2374	FH2374	Housing Assembly, 74" Fan, w/ Clips, FG	1
5	FH2732	FH2732	End Pivoting Shutter Clip, SS	6
6	FH2877	FH2877	Strut Mount Bracket, 74" Fan, GZ	2
7	FH2873	FH2873	C-Channel Strut, 74" Fan, GZ	2
8	FP2066	FP2066	Hub, Prop Adapter, 1.188"D. x 2.875"L., w/ Keyway, ZP	1
9	FM1465-ATS74HO	FM1465-ATS74HE	Assembly, Motor and Drive, Prgmd, ATS74, 460V	1
10	FH2879	FH2879	G2 Motor Mount Bracket, ATS74, GZ	2
11	FH2474	FH2474	G2 Motor Mount Brace, ATS74, GZ	1
12	FH1967	FH1967	Fixed Shutter clip, PL	2
13	PT74	PT74	Shutter, all plastic	1
14	FA2619	FA2619	Wind Bracket, GZ	2
15	AC1416	AC1416	Wind Pipe, GZ	1
16	FH2890	FH2890	Reinforcing Ring, 1/4 Section, Atlas74, PWDCTD, WHT	4
--	HP1169	HP1169	Hardware Pkg., Fan/Cone Install	1



Munters Aerotech Atlas74 Exhaust Fan with Munters Drive is developed and produced by GrainProteinTech Climate Control Air Treatment US, LLC.

2691 Ena Dr., Lansing, MI 48917 | 1-800-227-2376

© 2025 GRAIN AND PROTEIN TECHNOLOGIES.

All rights reserved. GrainProteinTech Climate Control & Air Treatment reserves the right to change designs and specifications without notice.

www.climatecontrolairtreatment.com