

User Manual

# Munters Aerotech Horizon CSI24 Continuous Sidewall Inlet -Flush

Models: CSI24100SF • CSI2410SF • CSI24100CF • CSI2410CF

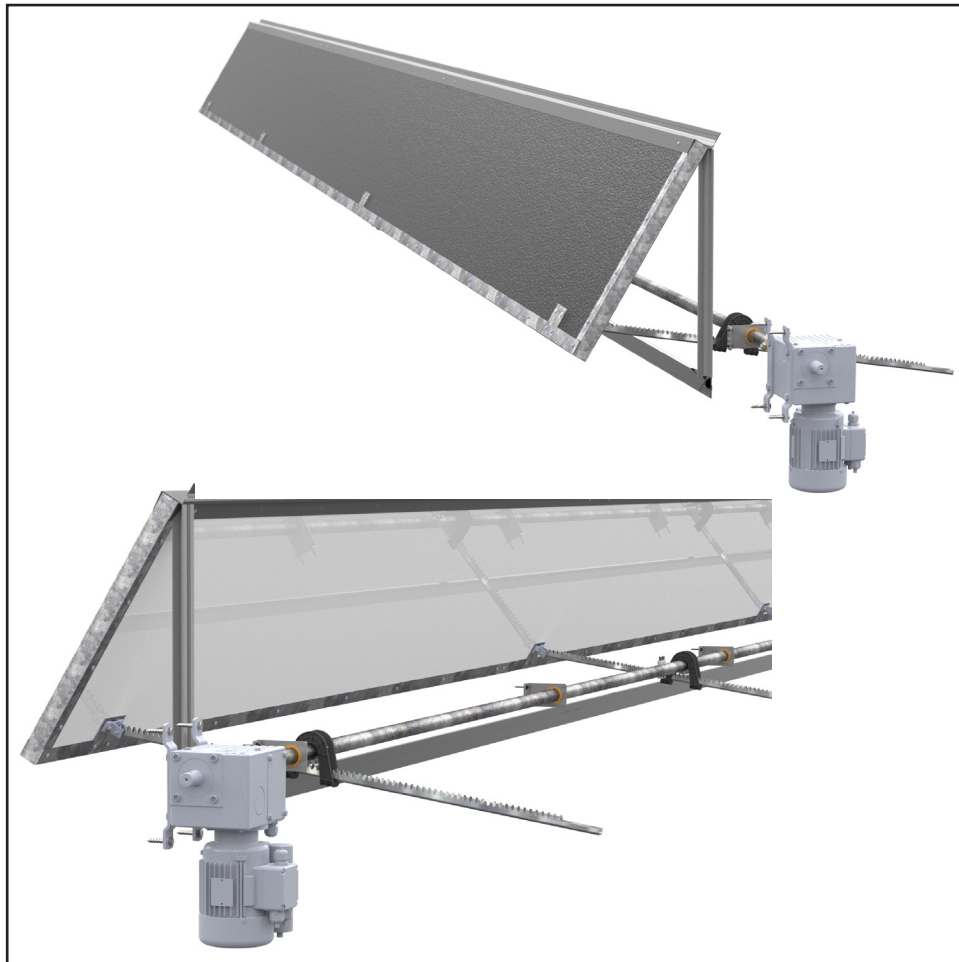

# Horizon CSI24 Flush Mount

## Instructions for Use and Maintenance

### Thank You:

Thank you for purchasing a Aerotech<sup>®</sup> Horizon CSI24 Continuous Sidewall inlet Flush. GrainProteinTech Climate Control & Air Treatment equipment is designed to be the highest performing, highest quality equipment you can buy. With the proper installation and maintenance it will provide many years of service.

### Please Note:

To achieve maximum performance and insure long life from your Aerotech<sup>®</sup> product it is essential that it be installed and maintained properly. Please read all instructions carefully before beginning installation.

### Warranty:

For Warranty claims information see the "Warranty Claims and Return Policy" form QM1021 available from the [Grain & Protein Technologies office at 1-800-227-2376](#) or by e-mail at [info@climatecontrolairtreatment.com](mailto:info@climatecontrolairtreatment.com).

### Conditions and Limitations:

- Products and Systems involved in a warranty claim under the "Warranty Claims and Return Policy" shall have been properly installed, maintained and operated under competent supervision, according to the instructions provided by Grain & Protein Technologies.
- Malfunction or failure resulting from misuse, abuse, negligence, alteration, accident or lack of proper installation or maintenance shall not be considered a defect under the Warranty.

# Index

Chapters	Page
<b>1. Unpacking the Equipment</b>	4
1.1 Catalog Number Definition	4
1.2 Parts List	4-6
<b>2. Installation Instructions</b>	7
2.1 Framing	7
2.2 Foam Seal	8
2.3 Door Assembly	9
2.4 Left Door Assembly	9
2.5 Middle Door Assembly	12
2.6 Right Door Assembly	14
2.7 Door Installation	17
2.8 Drive Frame Installation	22
2.9 Actuator Installation	26
2.10 Drive Pipe Preperation	26
2.11 Drive Pipe Installation	27
<b>3. Maintenance</b>	33

# Unpacking the Equipment

# 1.

Before beginning installation, check the overall condition of the equipment. Remove packing materials, and examine all components for signs of shipping damage. Any shipping damage is the customer's responsibility and should be reported immediately to your freight carrier.

## 1.1 System Description

The Munters CSI24 Continuous Sidewall Inlet is a 24"H. door that can be continuous for a total of 150'L. and can be mounted flush to the wall or offset so the drive pipe can be mounted away from the wall to avoid columns or posts. It can also use either Straight Racks or Curved Racks. The CSI24 Continuous Sidewall Inlet is sold in 100' Door Kits and 10' Door Kits, an Ending Kit and the Actuator (actuator sold separately). **For example:** For a system that is 450'L. with Offset Mount and Straight Racks, operated by 3 Actuators, the customer would receive the following: (4) CSI24100SF, (5) CSI2410SF, (3) AC2872 and (3) Actuators (actuator sold separately).

### Catalog Number Definition:

Door Kits

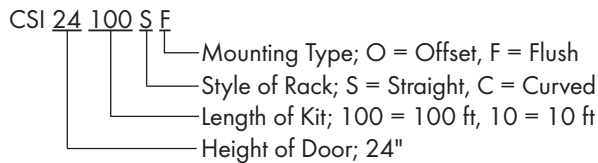

Ending Kits

- AC2871 = Straight Offset Mount Ending Kit
- AC2872 = Straight Flush Mount Ending Kit
- AC2873 = Curved Offset Mount Ending Kit
- AC2874 = Curved Flush Mount Ending Kit

## 1.2 Parts List

Each 10'L. CSI24 Door Kit, CSI24 Includes:

ID	CSI2410 Cat. No.	Qty.	Description
[1]	AC3470	1	Door w/ Hinge, 24"H. x 10'L. x 1.5"T., Blk/Wht, CSI24
[2]	AC3440	1	Door Edge Trim, 120"L., GZ
[3]	AC1415	1	1" SCHD10 (1.32"O.D.) Pipe x 126"L., SOE, 12GA, GZ
[4]	KA2156	2	Foam Seal, P-Shape w/ TAB, 2.14"W. x 1.31"H. x 60"L., BLK
[5]	AC3726	1	Straight Rack, 49"Travel, 57"(1450mm) L., GZ
	AC3737	1	Curved Rack, 49"Travel, 57"(1450mm) L., GZ

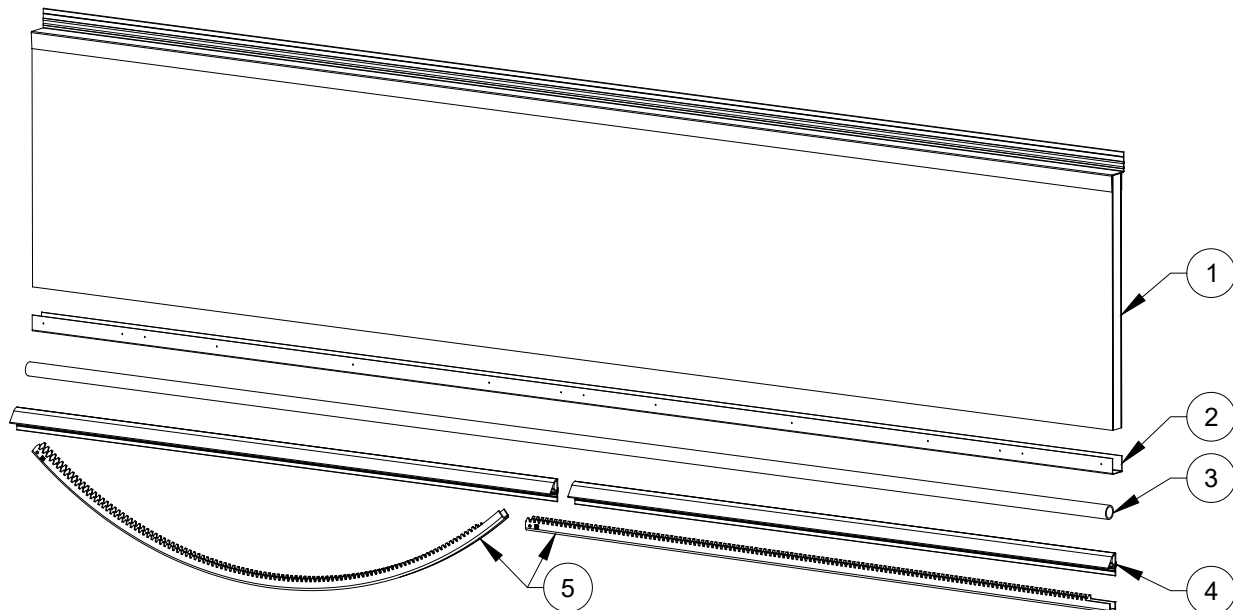

CSI2410 Door Kit

1.2 Parts (continued)

10'L. CSI24 Door Kit (continued)

ID	Cat. No.	Qty.	Description
[6]	AC3441	1	Flat Joiner Plate, 12"L., GZ
[7]	AC3720	1	Pinion Gear for 1" Pipe, AL
[8]	AC3708	1	Housing Rack Pinion Gear, PL
[9]	AC3722	1	Pivoting Connector, Rack to Door, AL
[A]	KP1257	1	Clevis Pin, 1/4"D x 2"L., ZP
[B]	KP1105	1	Hairpin Cotter Pin, 0.59"D x 1.13"L., SS
[C]	KS2808	2	M8-1.0, INT-HX, Set Screw, KNRL-CUP, ZP
[D]	KS1064	2	3/8"-16 x 2.25" Hex Bolt, ZP
[E]	KN1717	6	1/4"-20 Hex Flange Nylock Nut, SS
[F]	KS1513	6	1/4"-20 x 2.25" Carriage Bolt, ZP
[G]	KN1709	2	3/8"-16 Nylock Nut, ZP
[H]	KS2282	64	#10-16 x 3/4" HXWSR TEK Screw, SS
[J]	KS1402	64	#9-15 x 1 1/2" Seal Washer Polebarn Screw, ZP
[K]	KS2463	2	1/4" x 1 1/2" Lag Screw, ZP
[L]	KS1080	2	3/8"-16 x 1" Hex Bolt, ZP
[M]	KW3036	6	3/8" Flat Washer, USS, ZP
[10]	AC3407	1	Inside Door Support, 24", GZ
[11]	AC3417	1	Outside Door Support, 24", GZ
[12]	AC3410	2	Rack Mounting Plate, GZ
[13]	AC3704	1	Guide Plate w/BRNZ Bushing, 1" Pipe, L, GZ

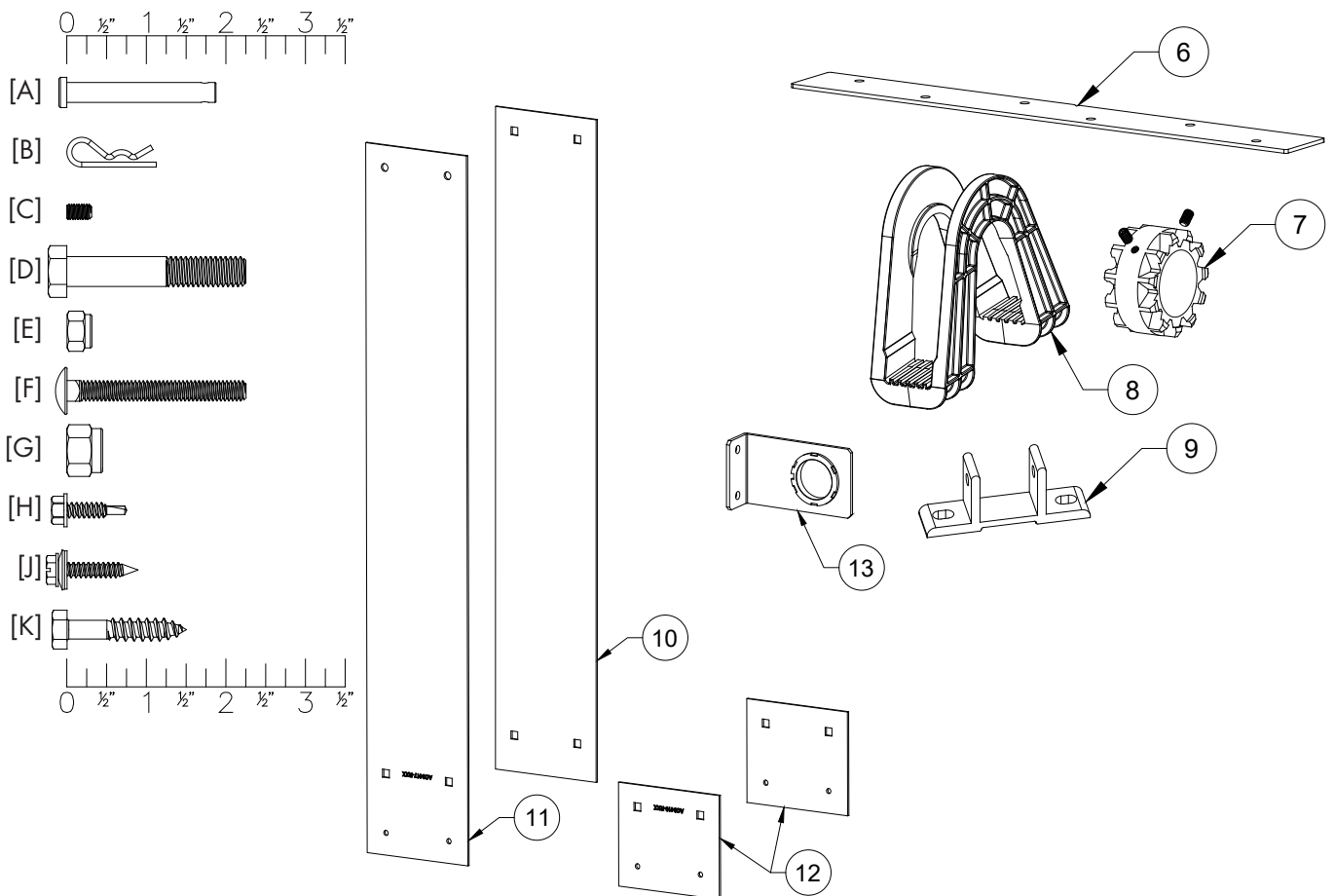

1.2 Parts (continued)

Each AC2872 Ending Kit, Flush, Straight Rack Includes:

ID	Cat. No.	Qty.	Description
[4]	KA2156	1	Foam Seal, P-Shape w/ TAB, 2.14"W. x 1.31"H. x 60"L, BLK
[5]	AC3726	1	Straight Rack, 49"Travel, 57"(1450mm) L, GZ
	AC3737	1	Curved Rack, 49"Travel, 57"(1450mm) L, GZ
[7]	AC3722	1	Pivoting Connector, Rack to Door, AL
[8]	AC3708	1	Housing Rack Pinion Gear, PL
[9]	AC3720	1	Pinion Gear for 1" Pipe, AL
[12]	AC3710	2	Rack Mounting Plate, GZ
[13]	AC3704	1	Guide Plate w/BRNZ Bushing, 1" Pipe, L, GZ
[15]	AC3484	2	Door End Trim, 24"L., CSI24, GZ
[16]	AC3706	1	Straight Coupling, Actuator to 1" Pipe, 3.5" to CL, GZ
[A]	KP1257	1	Clevis Pin, 1/4"D x 2"L., ZP
[B]	KP1105	1	Hairpin Cotter Pin, 0.59"D x 1.13"L., SS
[C]	KS2808	2	M8-1.0, INT-HX, Set Screw, KNRL-CUP, ZP
[D]	KS1064	3	3/8"-16 x 2.25" Hex Bolt, ZP
[E]	KN1717	13	1/4"-20 Hex Flange Nylock Nut, SS
[F]	KS1513	6	1/4"-20 x 2.25" Carriage Bolt, ZP
[G]	KN1709	3	3/8"-16 Nylock Nut, ZP
[H]	KS2282	20	#10-16 x 3/4" HXWSR TEK Screw, SS
[K]	KS2463	2	1/4" x 1 1/2" Lag Screw, ZP
[L]	KS2466	4	3/8" x 2" Lag Screw, ZP

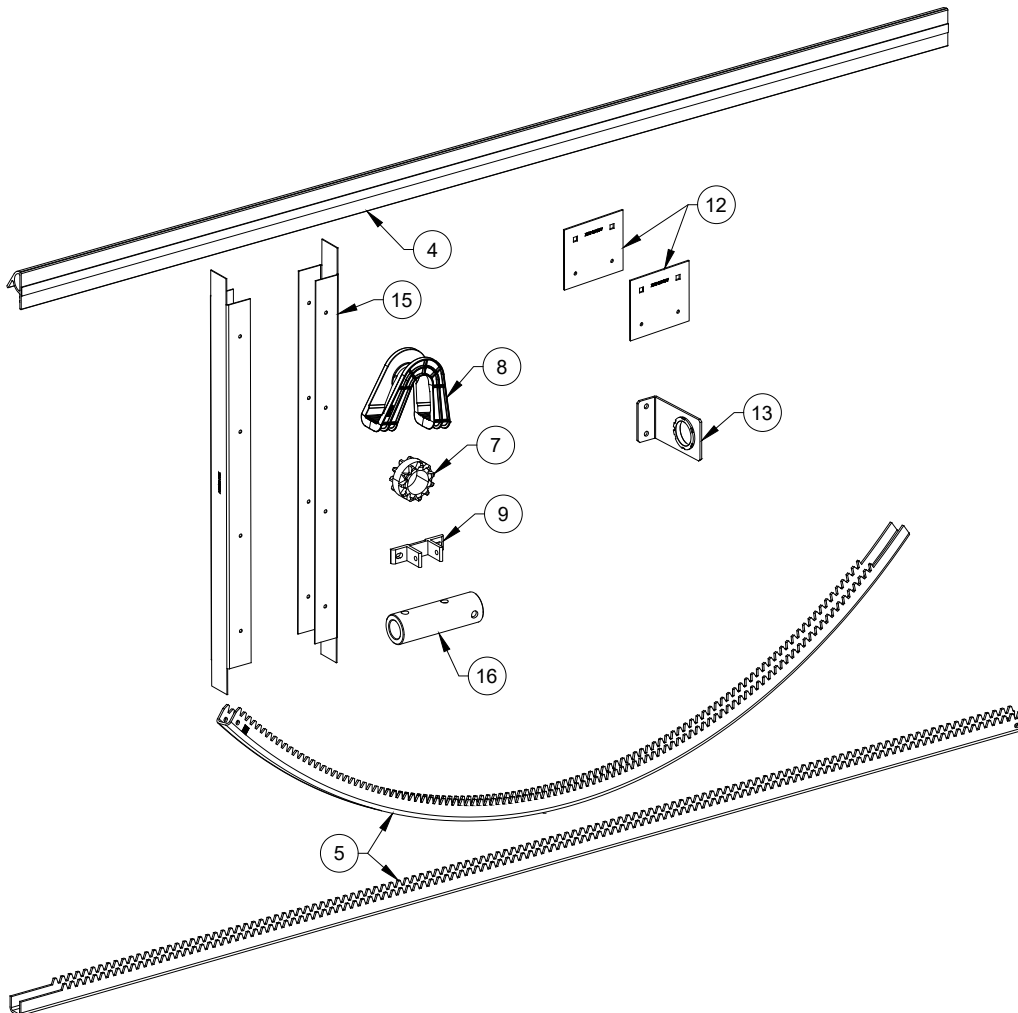
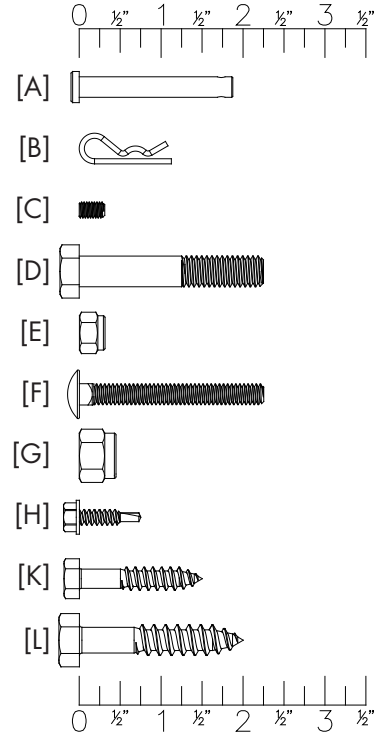

# Installation Instructions

# 2.

## 2.1 Framing

### Step 1A

The CS2410SF was designed for the door to be installed in the room and the Actuator and Pipe Drive system be mounted in the hallway. Construct the framed opening to correct size according to Chart A (below) and your CSI24 Continuous Sidewall Inlet size. See Chart A. If installing 2 or more sections of CSI24 doors, be sure to leave 24" minimum between each framed opening. See Figure 1A. Use Treated 2x6's for the Framing.

Catalog No.	Length	Height
Example	Door Length (-)4"	Door Height (-)2"
(1) CSI24100SF & (5) CSI2410SF (150'L. x 24"H.)	149'-8"	22"

Chart A

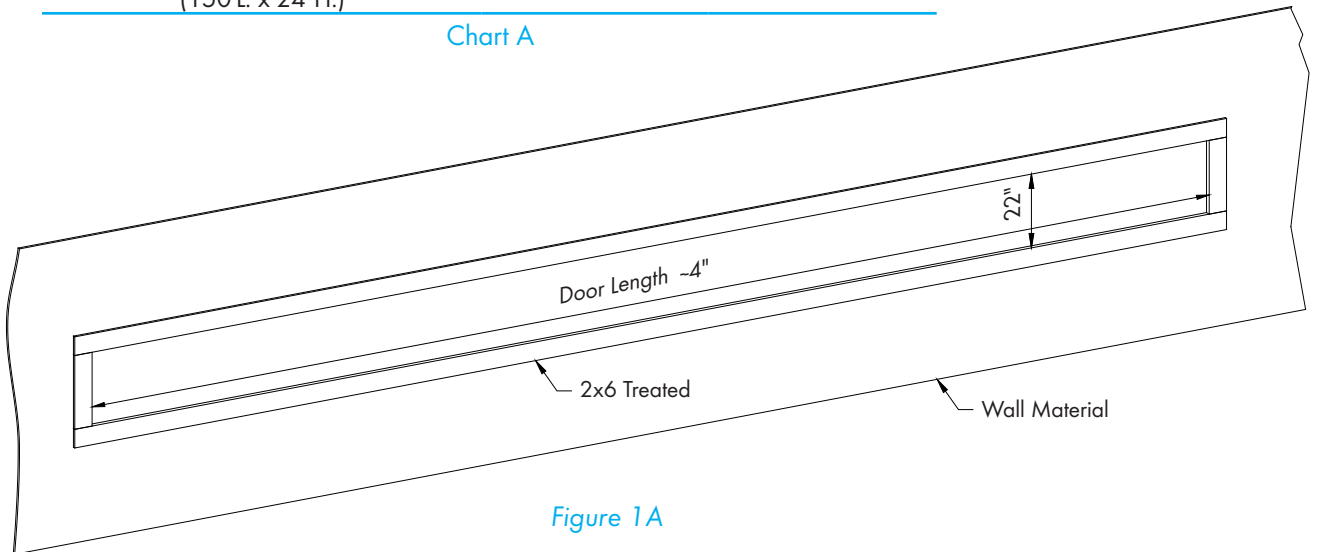

Figure 1A

### Step 1B

On the hallway side of the framing, install a treated 2x4, 18" from the end framing and then every 10'-0" O.C. down the length of the framing with the last 2x4 being 18" from the opposite end framing. These 2x4's should span the top and bottom framing. Also, install double treated 2x6's on the end of the framed opening to be used to moun the LA actuator to. See Figure 1B.

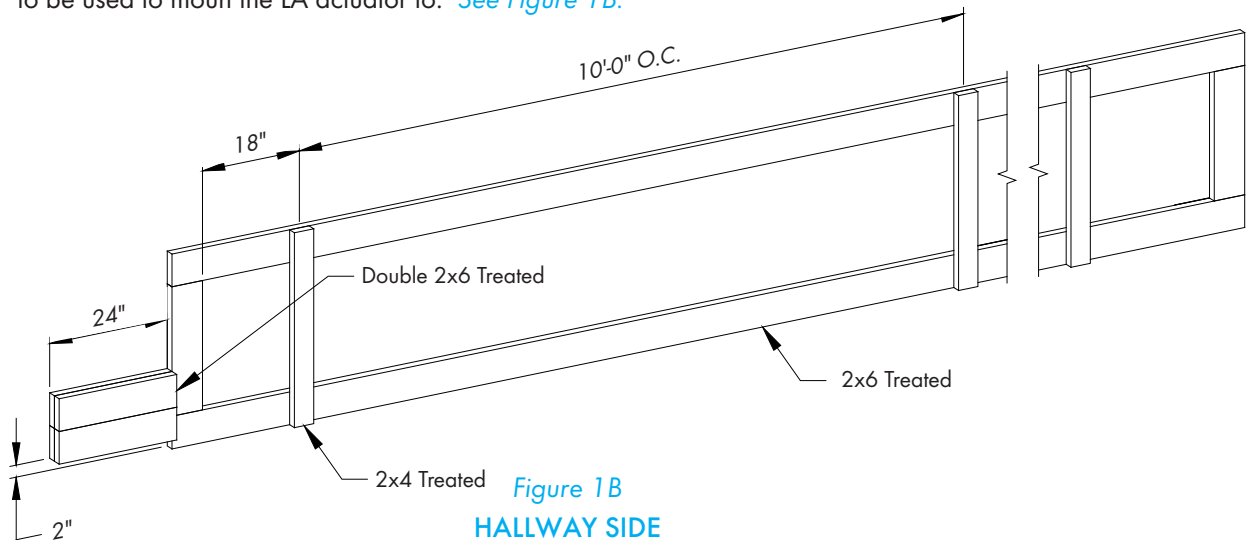

Figure 1B

HALLWAY SIDE

QM1217r1

## 2.2 Foam Seal

### Step 2

After the Framed Openings are completed, make sure the surface of the 2x lumber is clean and free from debris. The P-Shaped Foam Seal [4], comes in 60" lengths. Starting at 2" from the inside edge of the End Framing, so that it will overlap the side Foam Seal, peel the back from the adhesive on the back of the Foam Seal and affix to the framing with the top of the "P" flush with the top of the framing. *See Figure 2A and 2B.* For the Foam Seal on the End Framing, the top of the "P" should be flush with the inside edge of the framing and should run from the inside edge of the Top Framing to the bottom of the Foam Seal on the next frame member. *See Figure 2A and 2B.*

### Step 3

Continue attaching the P-Shaped Foam Seal until there is Foam Seal attached to 3 sides of each Framed Opening. Once the Foam Seal is completely attached, go back and permanently attach to the framing using Staples or Nails in the nailing groove of the Foam Seal Flap. Staples or Nails are not provided and should be spaced every 4" – 6". *See Figure 2A and 2B.*

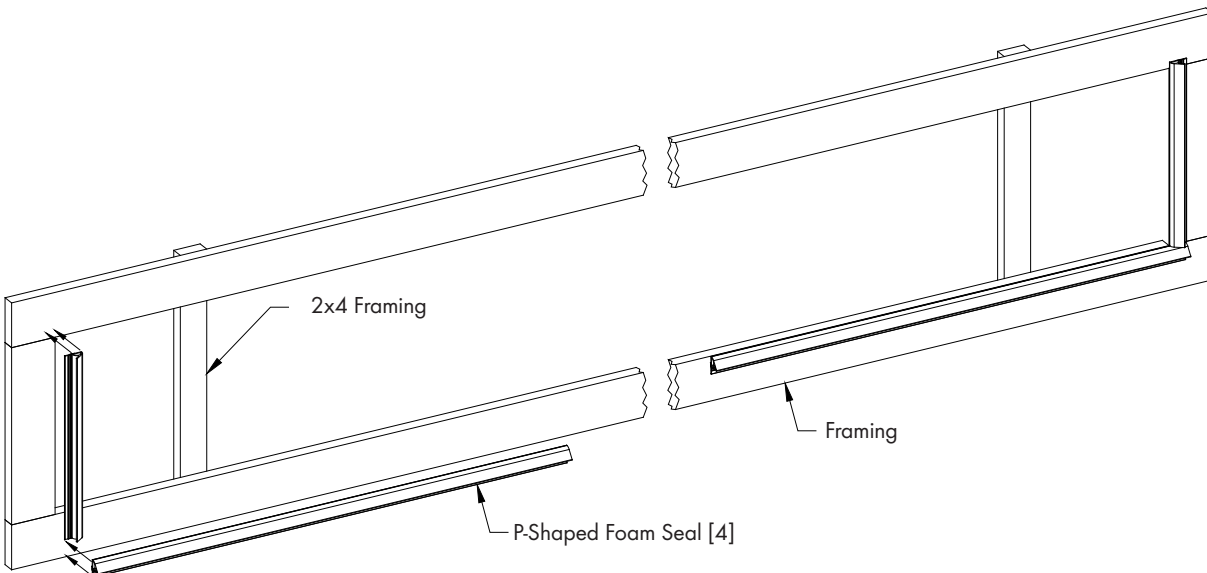

Figure 2A

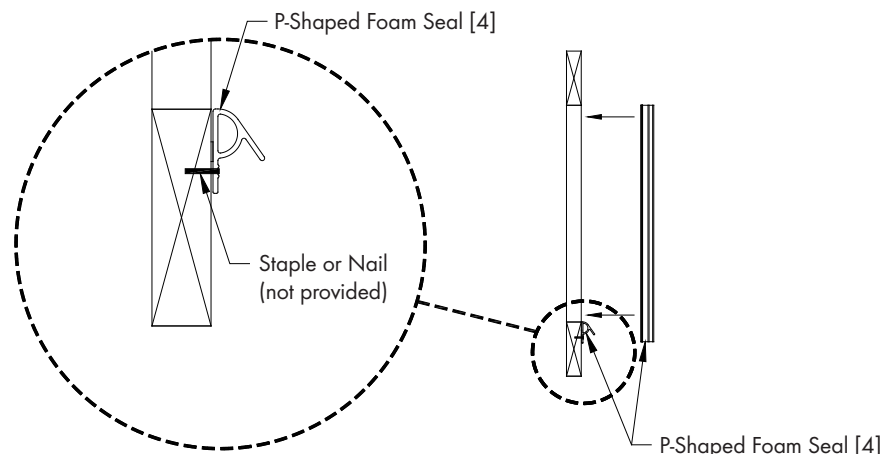

Figure 2B

QM1217r1

## 2.3 Door Assembly

### Step 4

Each CSI24 Inlet system that is 30'L. or longer consists of (1) Left Door, (1 or more) Middle Doors and (1) Right Door. The number of Middle Doors depends on the length of the run of CSI24 Doors. For example, if the run of CSI24 Doors is 40'L. then there is (1) Left Door, (2) Middle Doors and (1) Right Door. If the run is 100'L. then there is (1) Left Door, (8) Middle Doors and (1) Right Door. In the next steps all the doors will be assembled before installing them to the framed openings. See Figure 3. If the run is only 20'L. then there is only the Left Door and the Right Door.

**NOTE:** The Left and Right ends of the system are determined from the Hallway/Actuator side of the inlet, with the inlet mounted in the room.

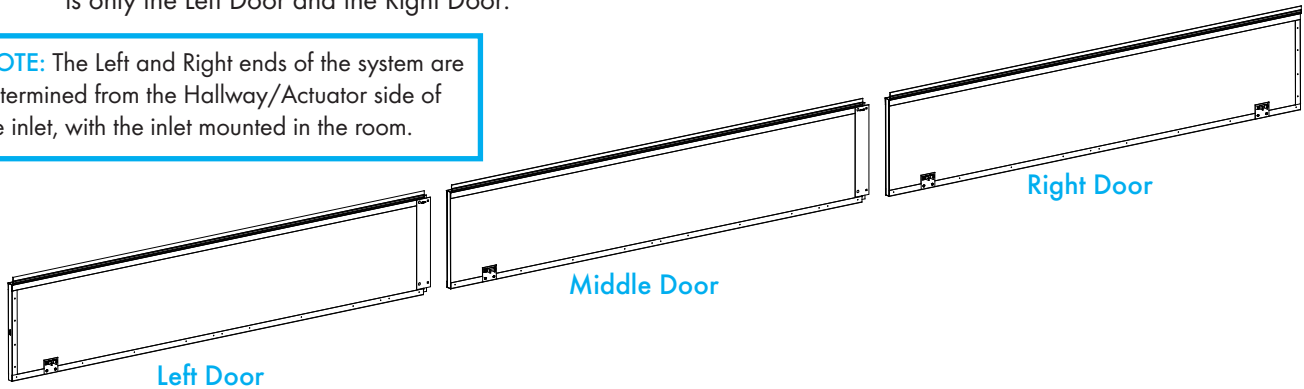

Figure 3  
View from Hallway/Hinge Side

## 2.4 Left Door Assembly

### Step 5

Slide Door Edge Trim [2] onto the bottom edge of the CSI24 Door [1] and secure it with (14) TEK Screws [H] through the (6) single holes in the middle area of the Door Edge Trim and the left most hole. See Figure 4.

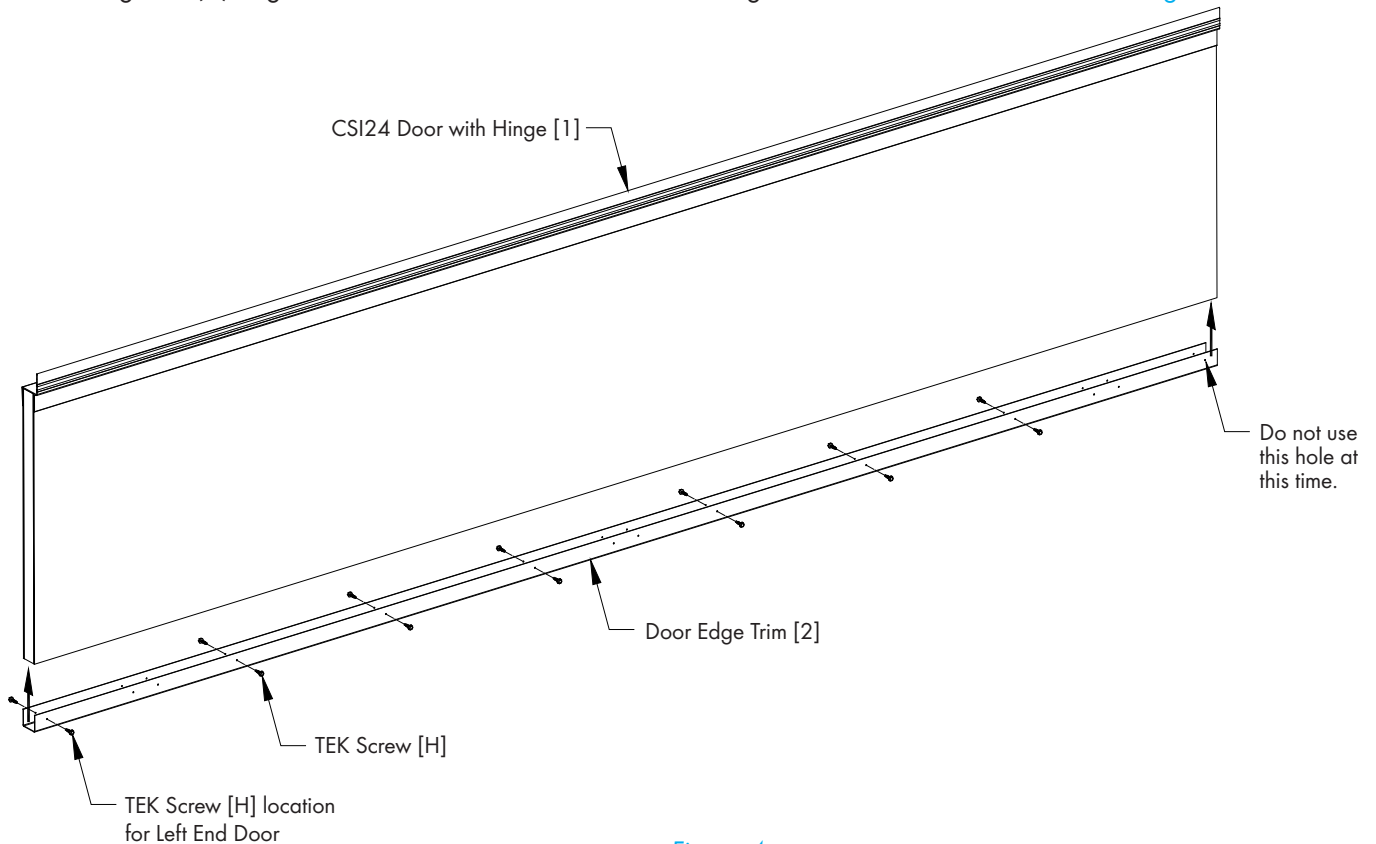

Figure 4

QM1217r1

Step 6

Slide a Door End Trim [15] over the Left Door and secure in place with (8) TEK Screws [H]. See Figure 5.

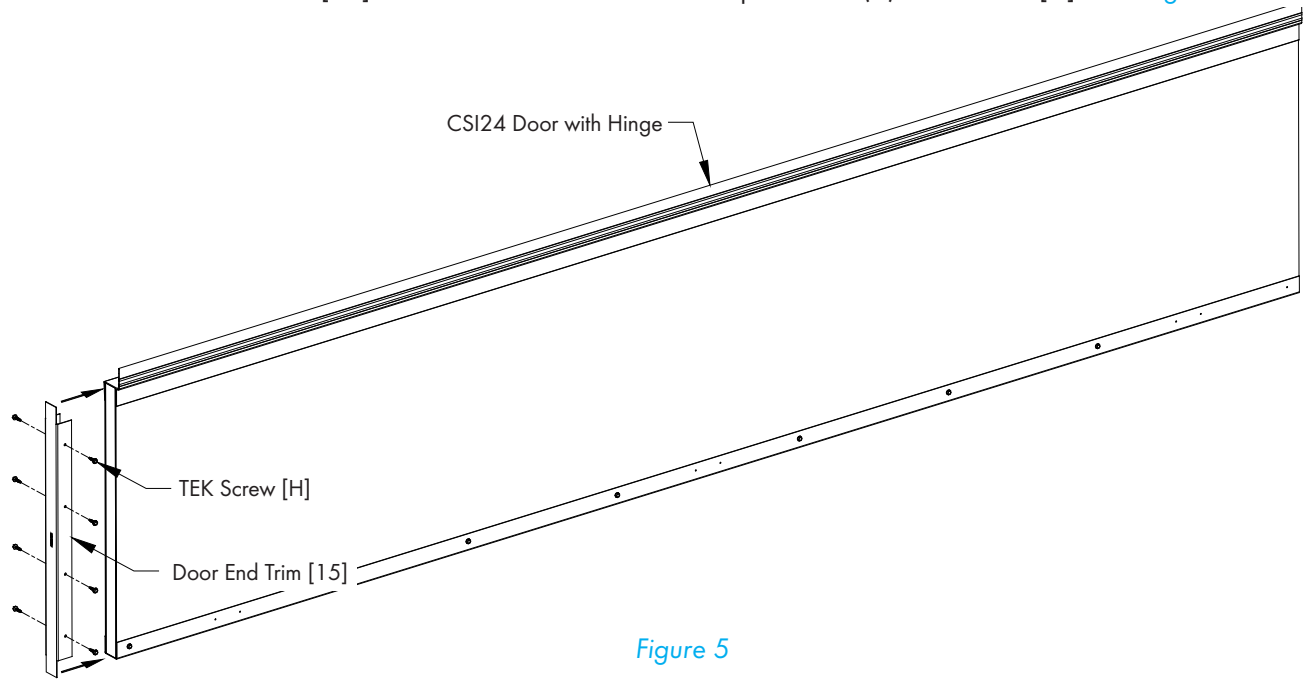

Figure 5

Step 7

For the Left Door, attach a Rack Mounting Plate [12] on each side of the door to the left pair of holes in the Door Edge Trim using (2) TEK Screws [H] per Plate. See Figure 6. Then attach an Outside Door Support [11] (24") at the right end of the CSI24 Door, on the room side, so that half of the Support is on the Door and the other half of the Support hangs off the end. See Figure 6.

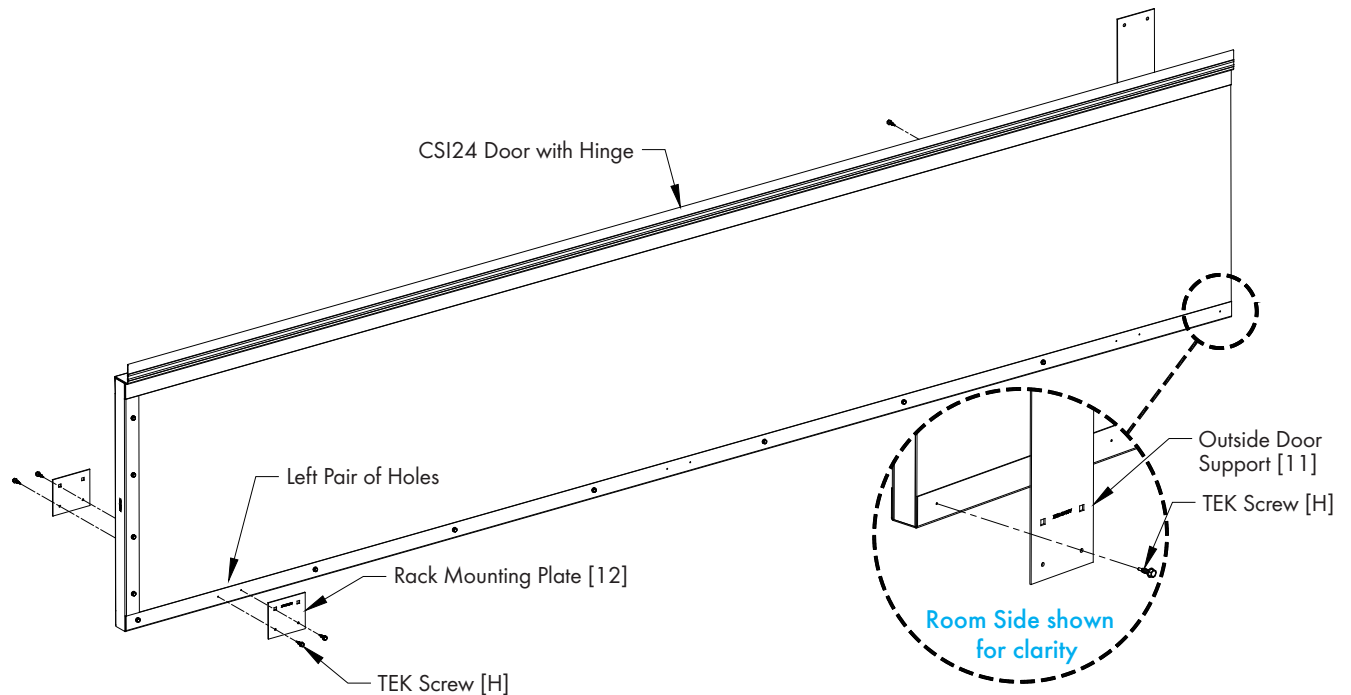

Figure 6

QM1217r1

**Step 8**

Drill a  $\frac{1}{32}$ " hole through the CSI24 Door using the Square Holes in the Rack Mounting Plate [12] as a guide. See Figure 7. Make sure the holes go through the holes on one side of the door, through the holes on the other side. Also, drill a  $\frac{1}{32}$ " hole through the 2 holes in the Outside Door Support [11]. See Figure 7.

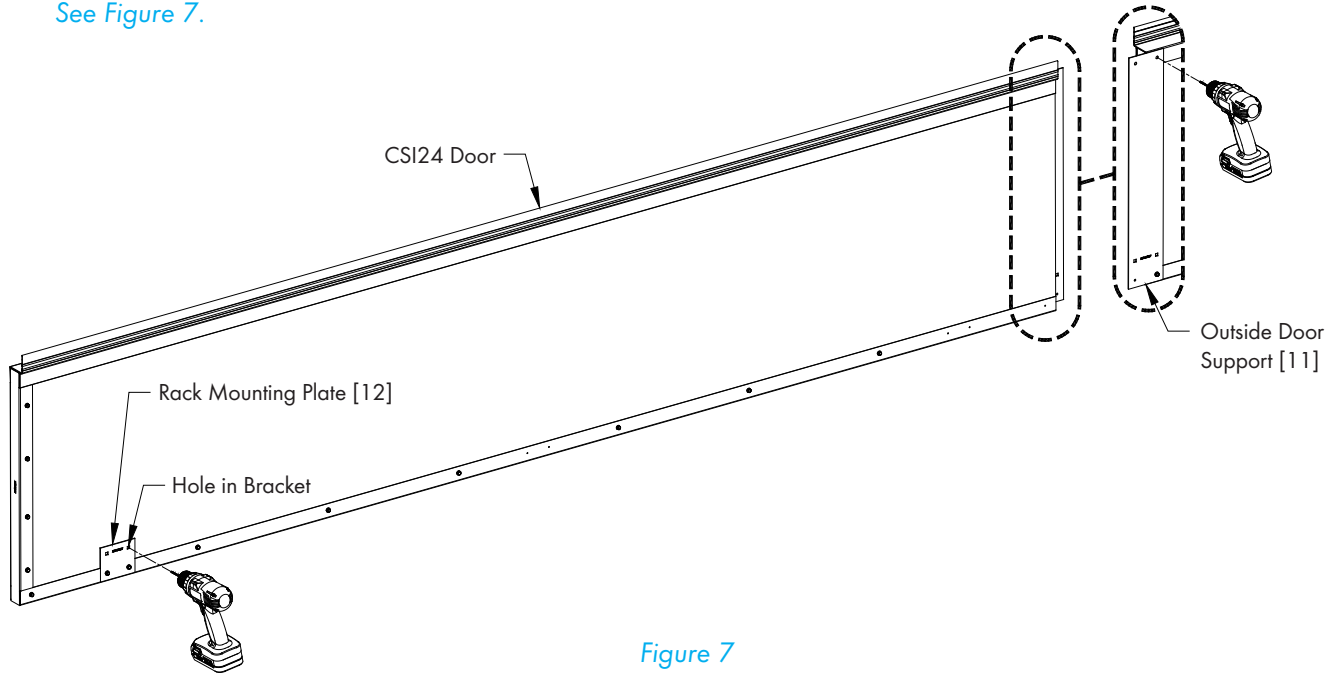

Figure 7

**Step 9**

Fasten Inside Door Support [10] to back of CSI24 Door in line with Outside Door Support [11] using (2) Carriage Bolts [F] and Nylock Nuts [E] with the Carriage Bolts on the Hinge side of the door. See Figure 8. Secure the Pivoting Connector [9] to the Pair of holes in Rack Mounting Plate on Hinge Side using (2) Carriage Bolts [F] and Nylock Nuts [E], with the Nuts on the Pivoting Connector. See Figure 8.

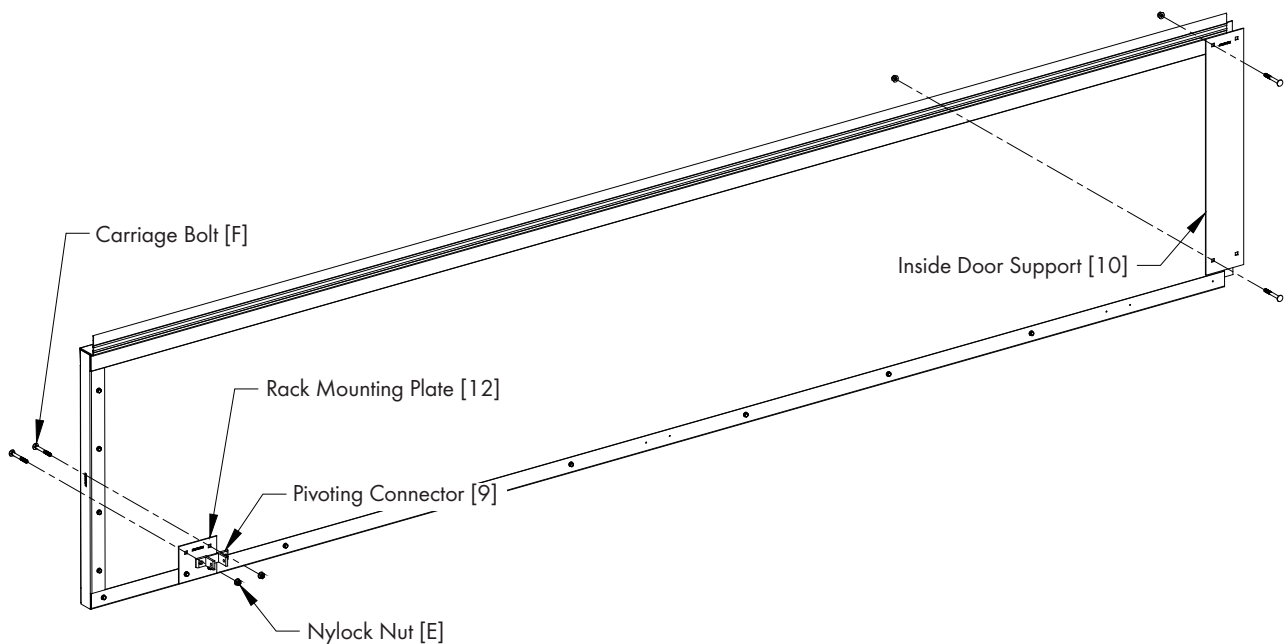

Figure 8

## 2.5 Middle Door Assembly

### Step 10

Slide Door Edge Trim [2] onto the bottom edge of the CSI24 Door [1] and secure it with (12) TEK Screws [H] through the (6) single holes in the middle area of the Door Edge Trim, leave the left most and right most holes empty. See Figure 9.

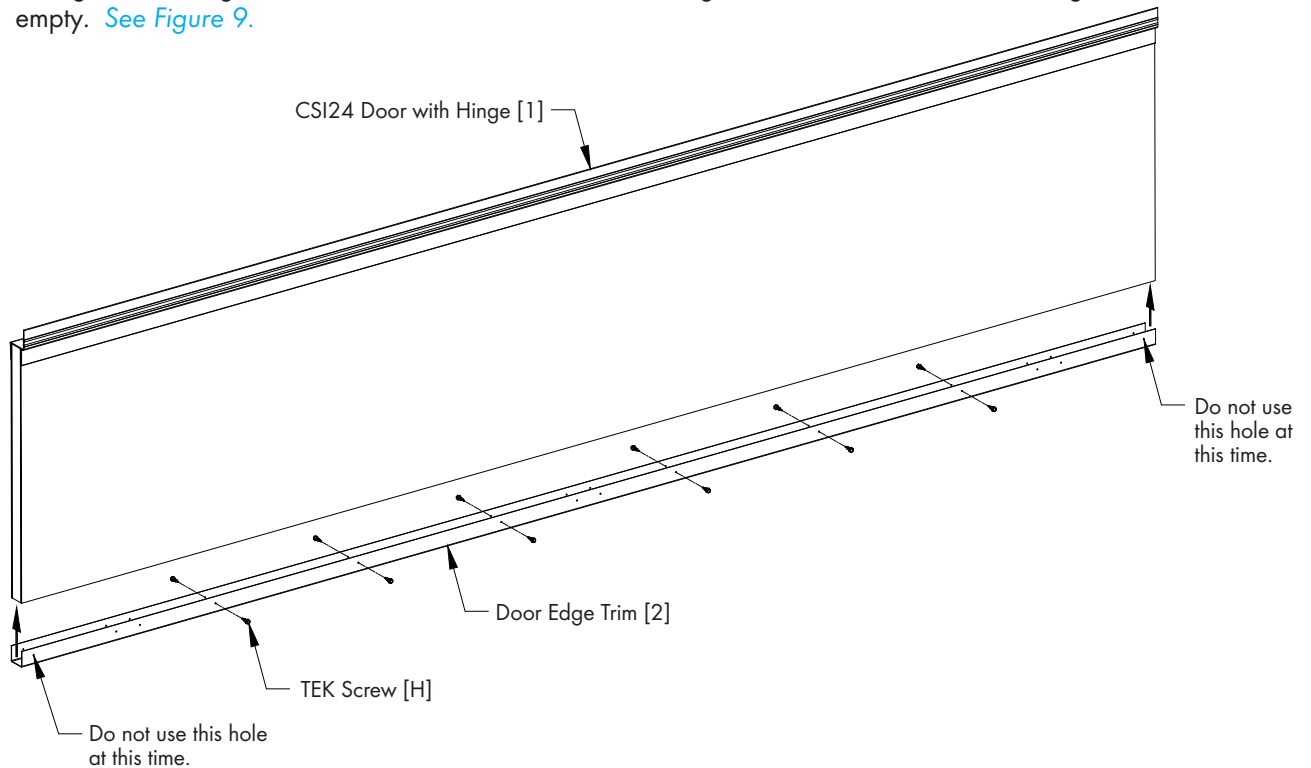

Figure 9

### Step 11

Attach a Rack Mounting Plate [12] on each side of the door to the left pair of holes in the Door Edge Trim using (2) TEK Screws [H] per Plate. See Figure 10. Then attach an Outside Door Support [11] (24") at the right end of the CSI24 Door, on the room side, so that half of the Support is on the Door and the other half of the Support hangs off the end. See Figure 10.

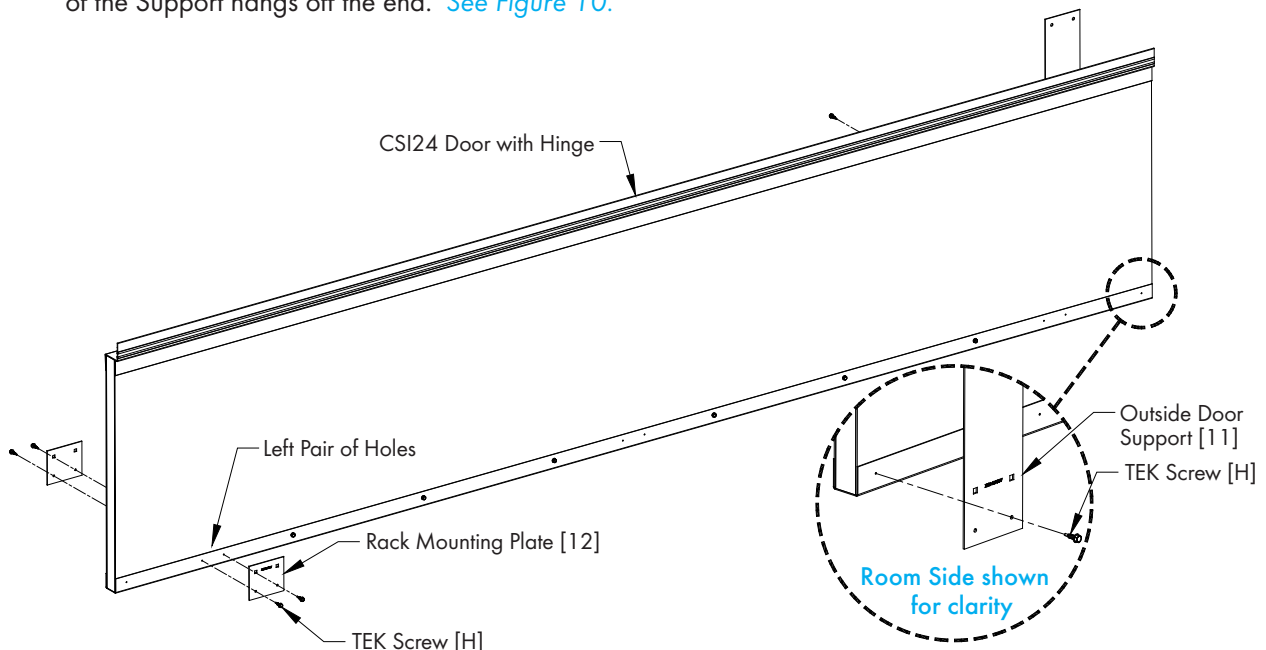

Figure 10  
QM1217r1

**Step 12**

Drill a  $\frac{3}{32}$ " hole through the CSI24 Door using the Square Holes in the Rack Mounting Plate [12] as a guide. See Figure 11. Make sure the holes go through the holes on one side of the door, through the holes on the other side. Also, drill a  $\frac{3}{32}$ " hole through the 2 holes in the Outside Door Support [11]. See Figure 11.

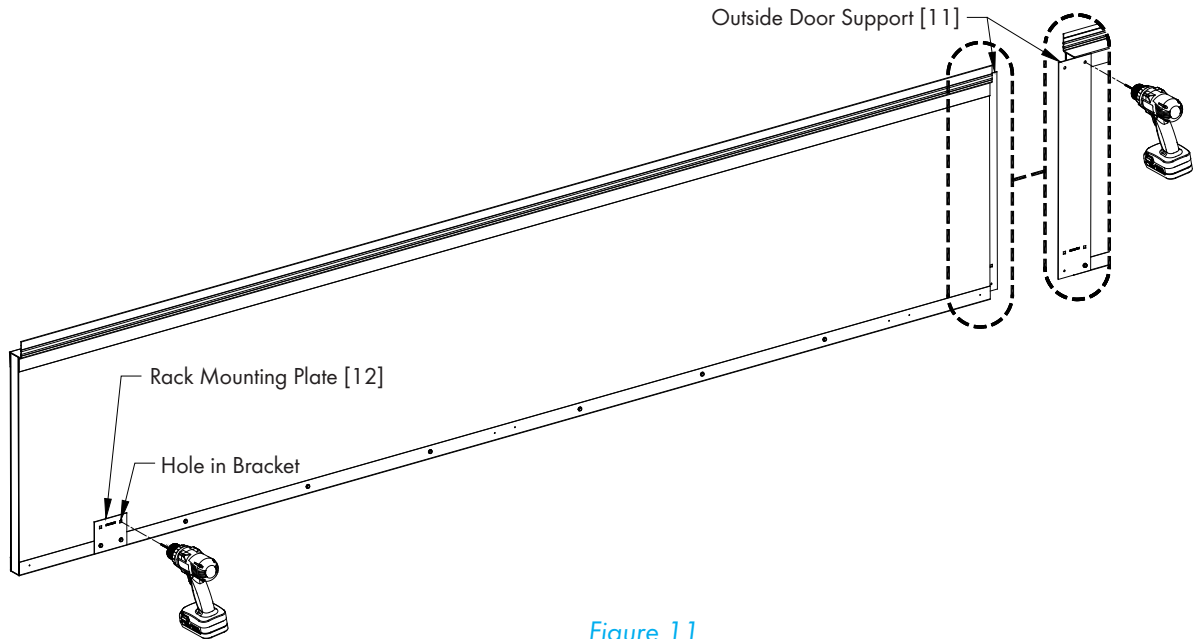

Figure 11

**Step 13**

Fasten Inside Door Support [10] to back of CSI24 Door in line with Outside Door Support [11] using (2) Carriage Bolts [F] and Nylock Nuts [E] with the Carriage Bolts on the Hinge side of the door. See Figure 12. Secure the Pivoting Connector [9] to the Pair of holes in Rack Mounting Plate on Hinge Side using (2) Carriage Bolts [F] and Nylock Nuts [E], with the Nuts on the Pivoting Connector. See Figure 12.

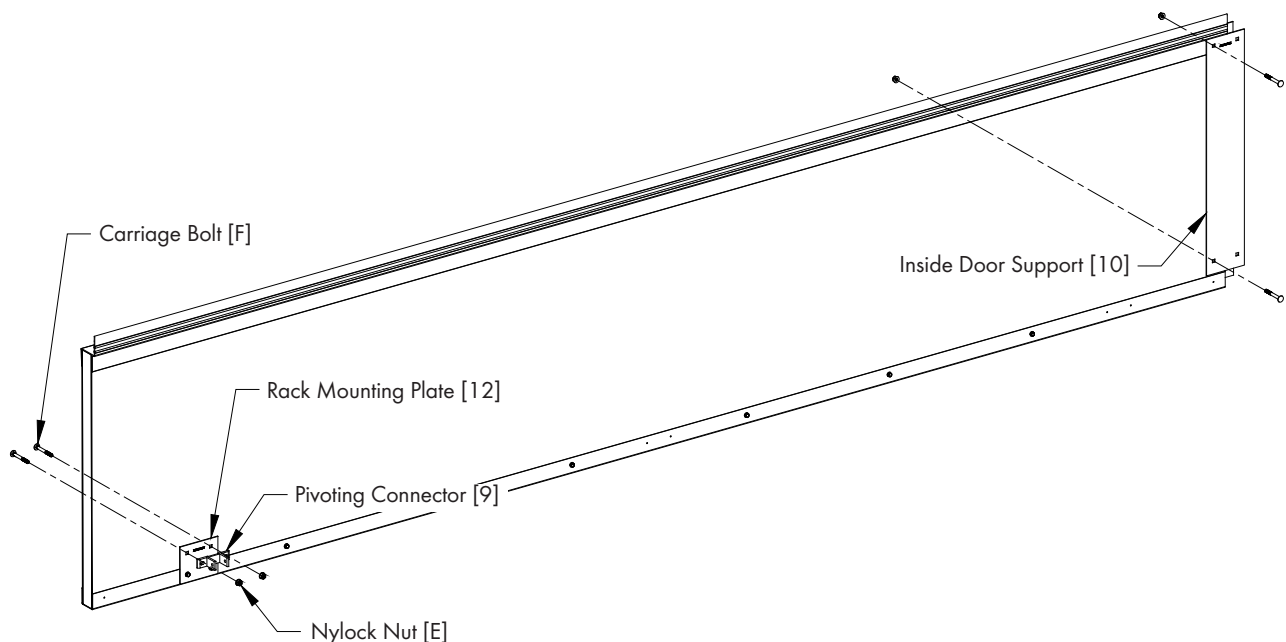

Figure 12

QM1217r1

## 2.6 Right Door Assembly

### Step 14

Slide Door Edge Trim [2] onto the bottom edge of the CSI24 Door [1] and secure it with (14) TEK Screws [H] through the (6) single holes in the middle area of the Door Edge Trim and the right most hole. [See Figure 13.](#)

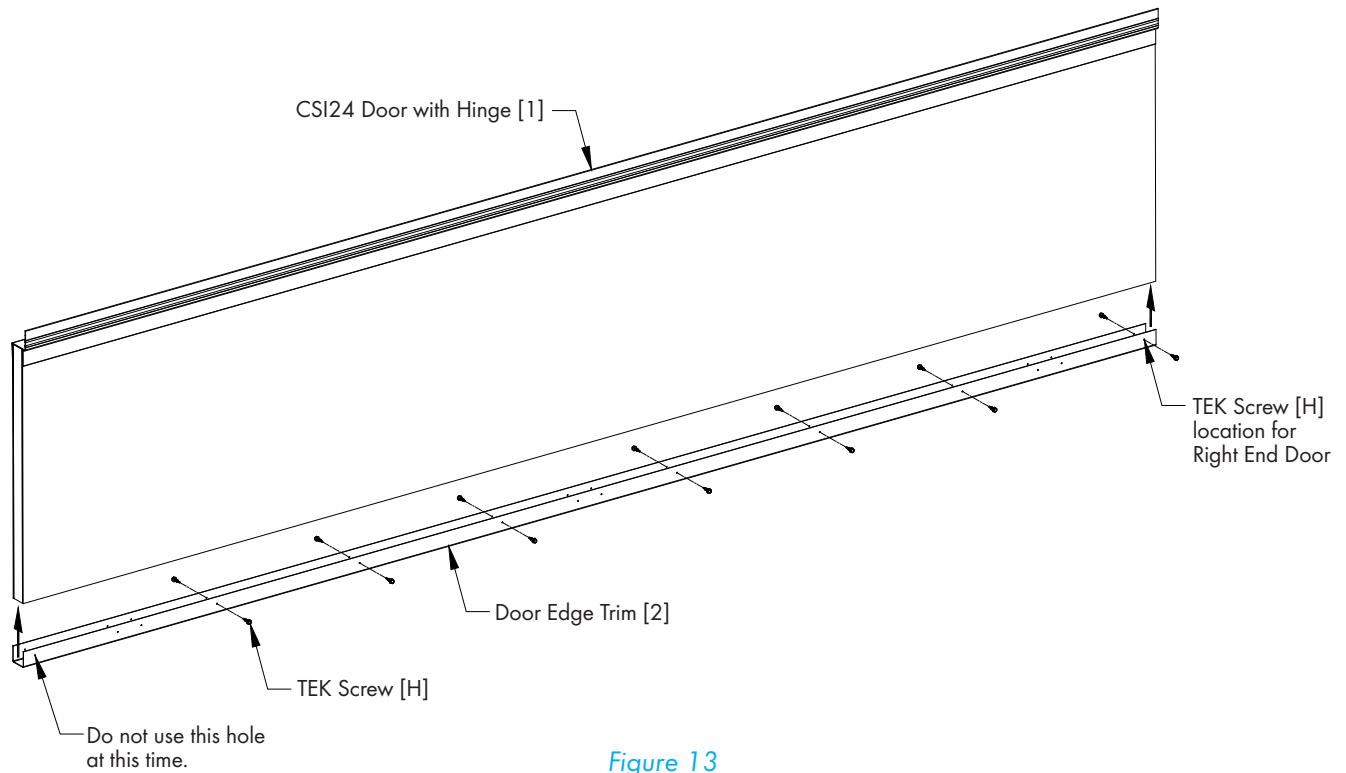

Figure 13

### Step 15

Slide a Door End Trim [15] over the Left Door and secure in place with (8) TEK Screws [H]. [See Figure 14.](#)

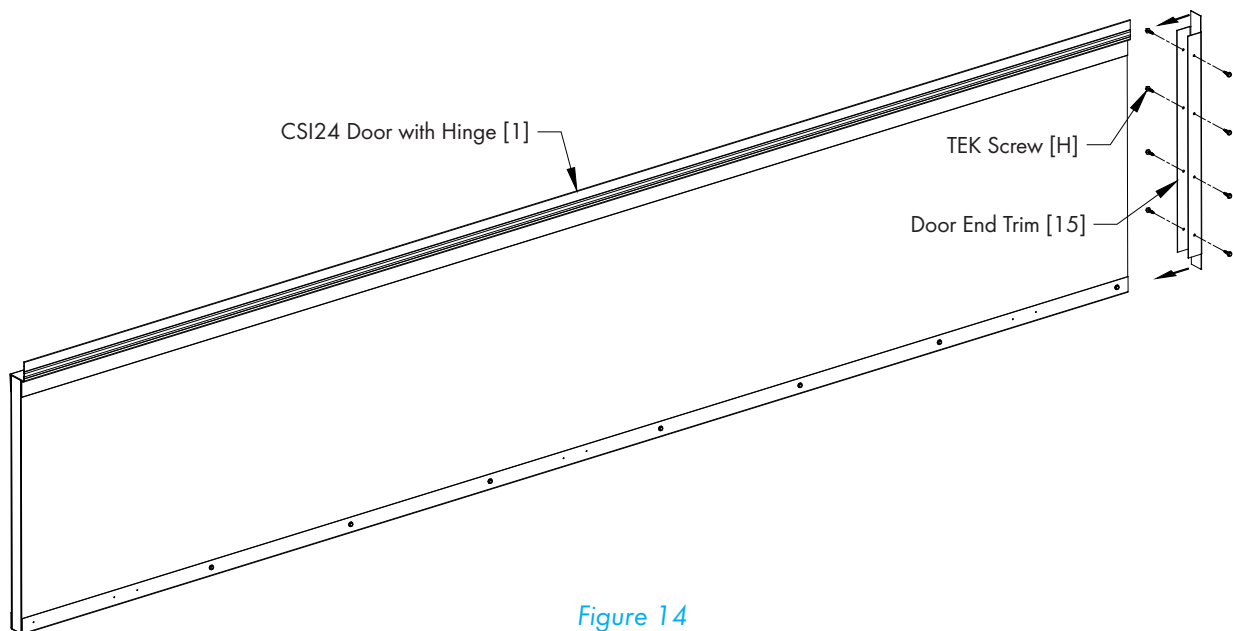

Figure 14

**Step 16**

Attach (2) Rack Mounting Plates [12] on each side of the door to the left pair of holes and to the right pair of holes in the Door Edge Trim using (2) TEK Screws [H] per Plate. [See Figure 6.](#)

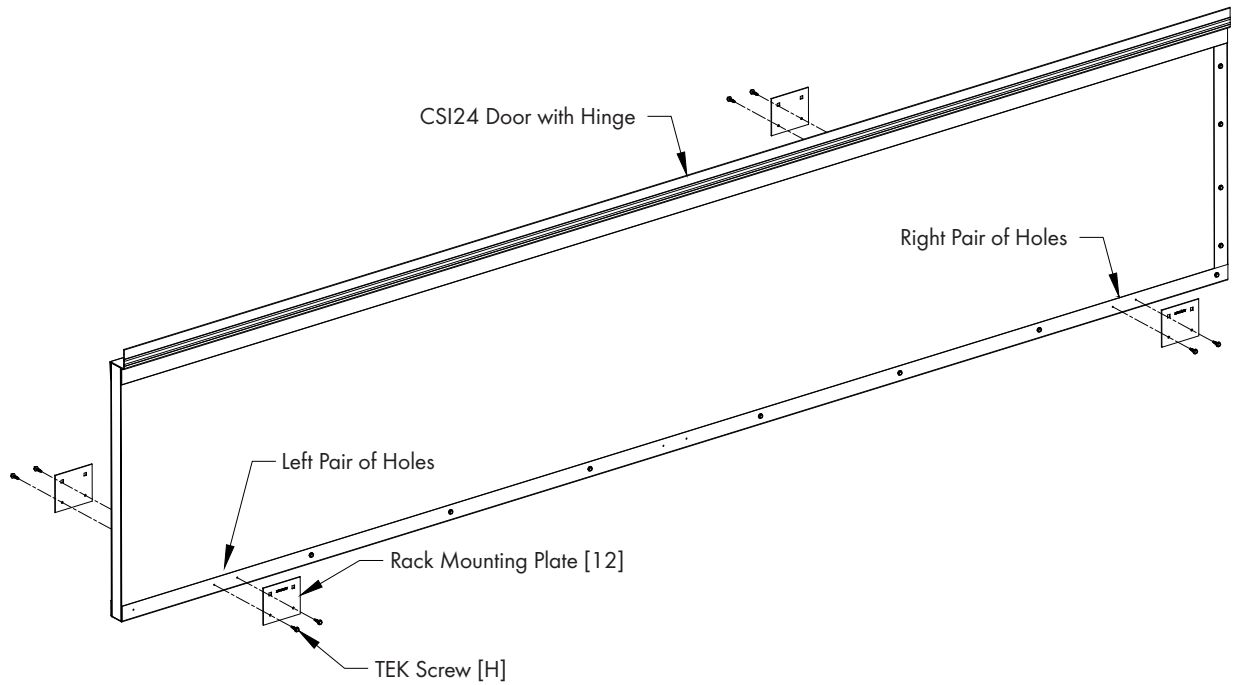

Figure 15

**Step 17**

Drill a  $\frac{1}{32}$ " hole through the CSI24 Door using the Square Holes in the Rack Mounting Plate [12] as a guide. [See Figure 11.](#) Make sure the holes go through the holes on one side of the door, through the holes on the other side.

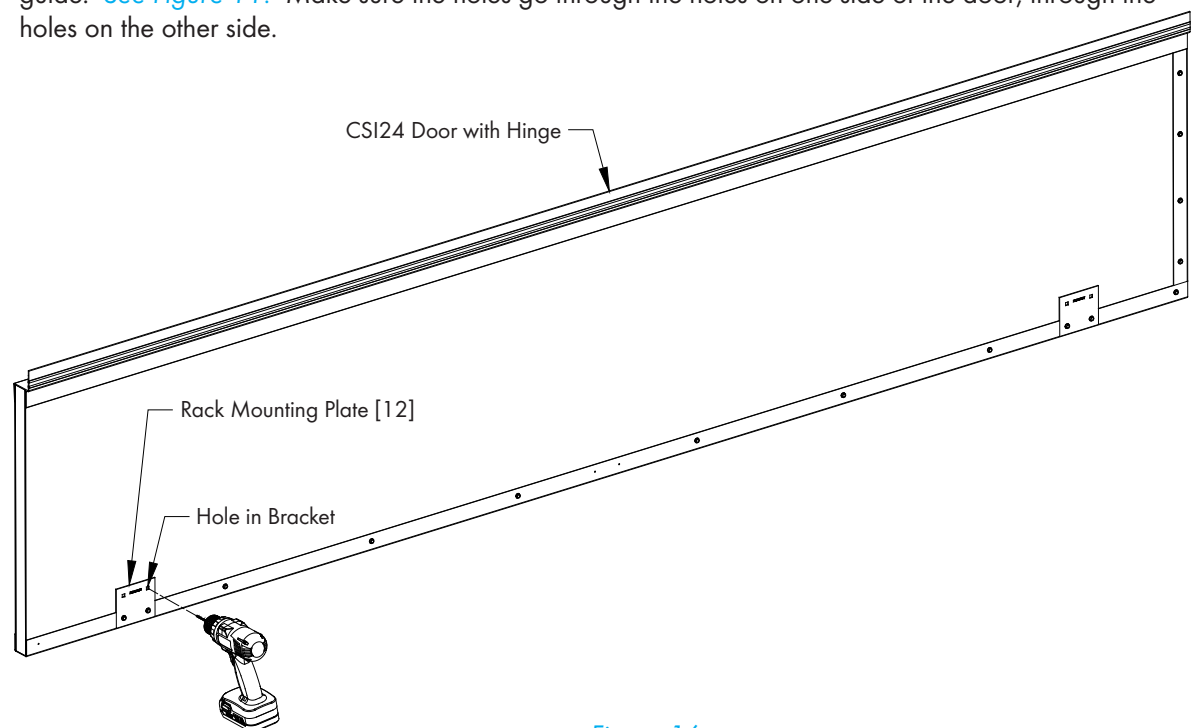

Figure 16

Step 18

Secure a Pivoting Connector [9] to the Pair of holes in each Rack Mounting Plate on Hinge Side using (2) Carriage Bolts [F] and Nylock Nuts [E], with the Nuts on the Pivoting Connector. See Figure 17.

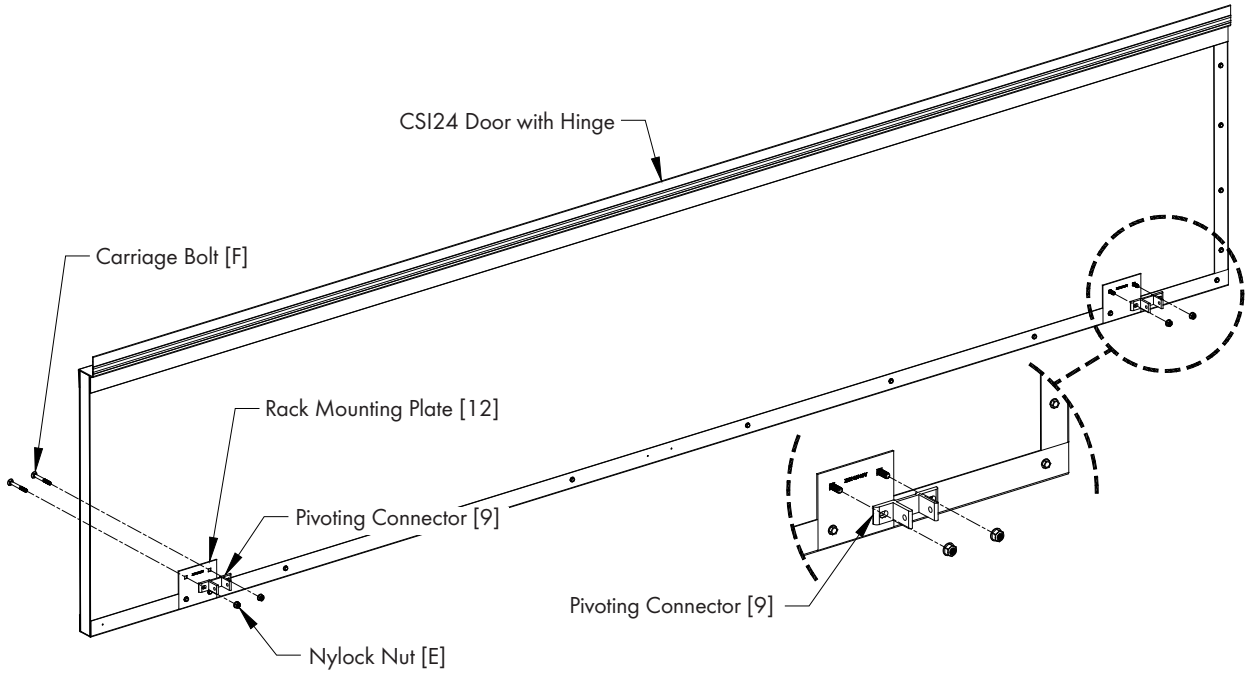

Figure 17

## 2.7 Door Installation

### Step 19

Begin hanging the CSI24 Doors by snapping a chalk line 2½" up from the bottom edge of the Top Framing piece. Then hold a Left CSI24 Door in place with the Top Edge of the CSI24 Door Hinge aligned with chalk line and the End of the Door overlapping the End Framing by 2" and attach Left CSI24 Door to Framing using Polebarn Screws [J]. The first screw should be 2" from the end and space the rest of the screws 4" apart.

See Figure 18.

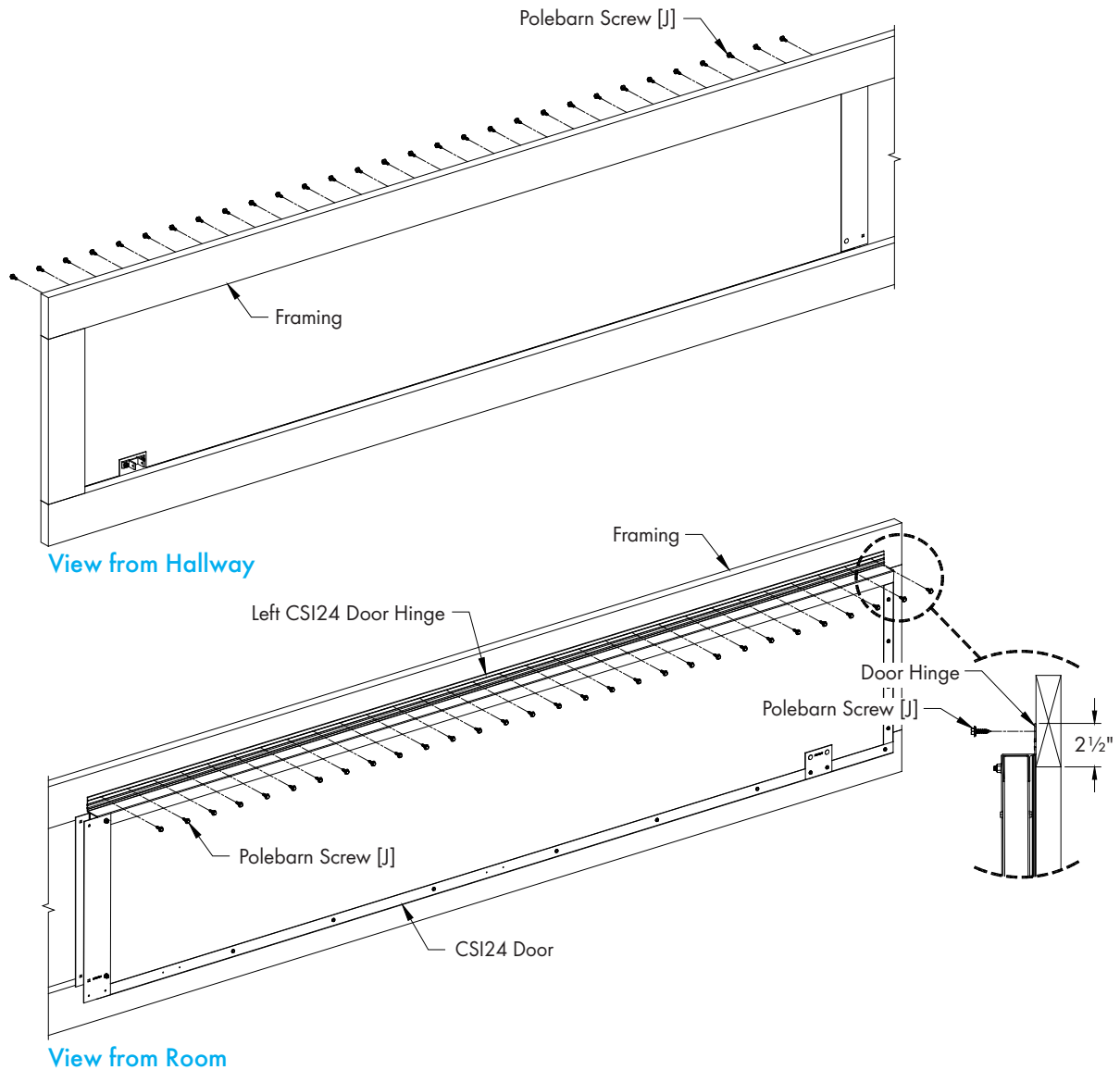

Figure 18

**Step 20**

Apply a Bead of Caulk (not provided) to the end of the Middle CSI24 Door that will attach to left door. Carefully slide caulked end of Middle CSI24 Door in between the Outside Door Support and Inside Door Support on the end of Left Door. Align Middle CSI24 Door Hinge to chalk line and hold firmly against installed CSI24 Door and attach to framing using Polebarn Screws [J] spaced 4" apart. See Figure 19.

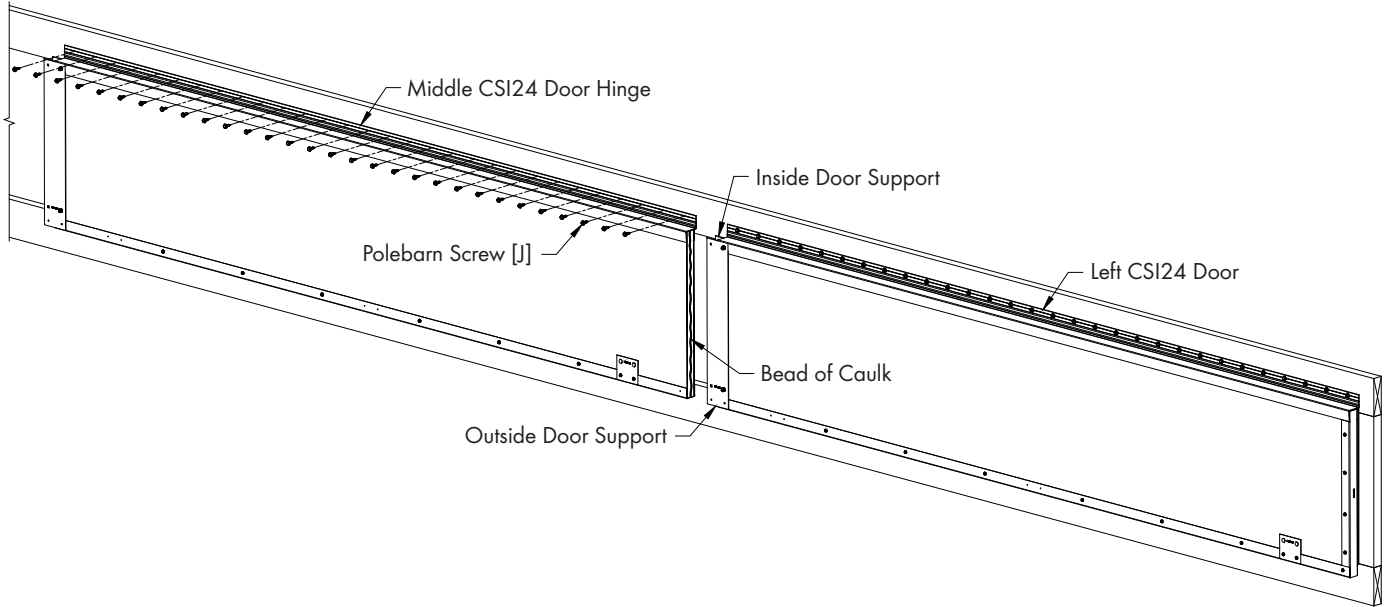

Figure 19

**Step 21**

Secure Outside Door Support from Left Door to Middle Door using (1) TEK Screws [H]. Then using the round hole and square hole as a guide, drill (2) 3/32" holes through Middle Door. See Figure 20. Make sure the drill bit goes through straight and goes through the holes in the Inside Door support.

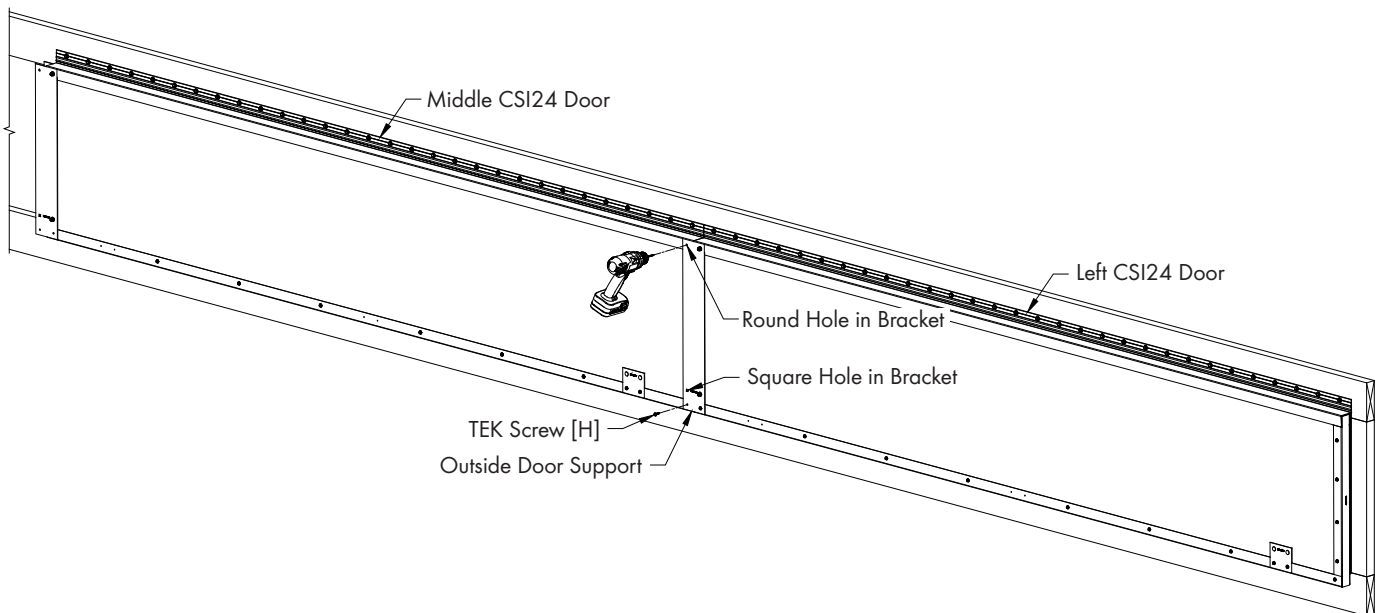

Figure 20

**Step 22**

Secure Left Door and Middle Door together with (2) Carriage Bolts [F] and Nuts [E] through (2) holes in Inside and Outside Door Supports. See [Figure 21](#). Apply a bead of caulk to the joint between doors at the hinge and the top of the doors.

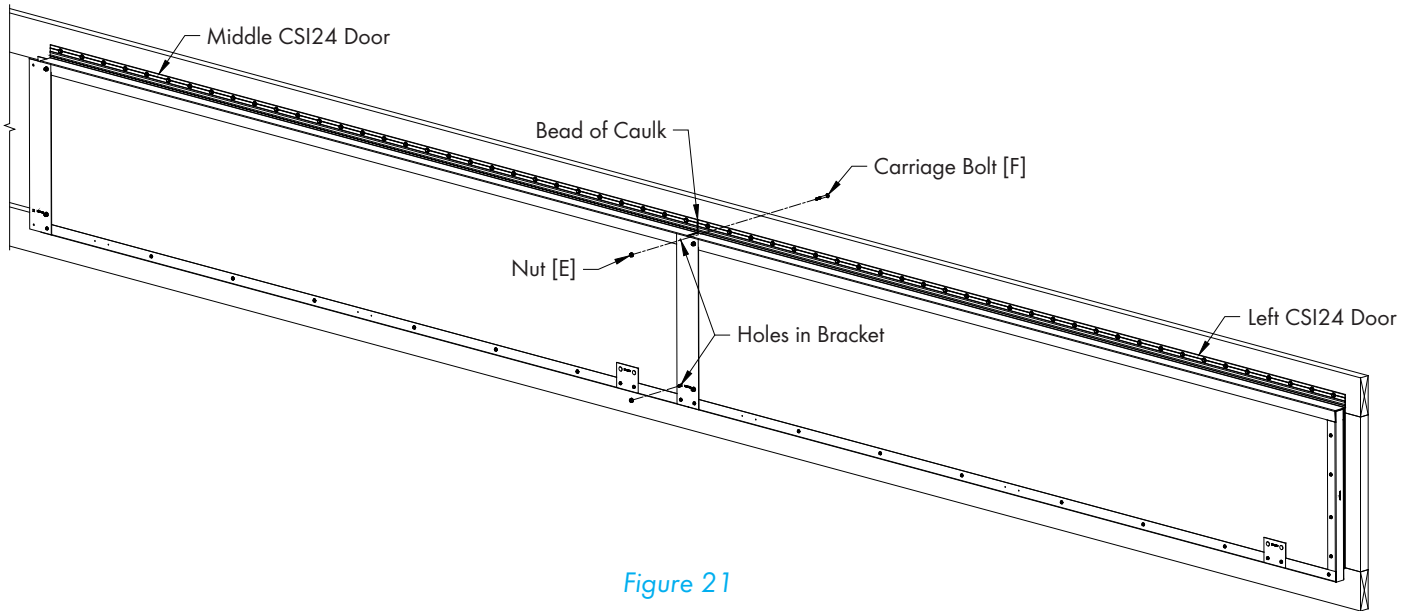

Figure 21

**Step 23**

Repeat [Steps 20, 21 and 22](#) for the remainder of the Middle Doors in the row until you just have the Right CSI24 Door to install.

**Step 24**

When the Right CSI24 Door is installed, tight against the last Middle Door, it should overlap the right End Framing by 2". If needed, the left end of the Right CSI24 Door may be trimmed to allow proper fit and overlap. See [Figure 22](#).

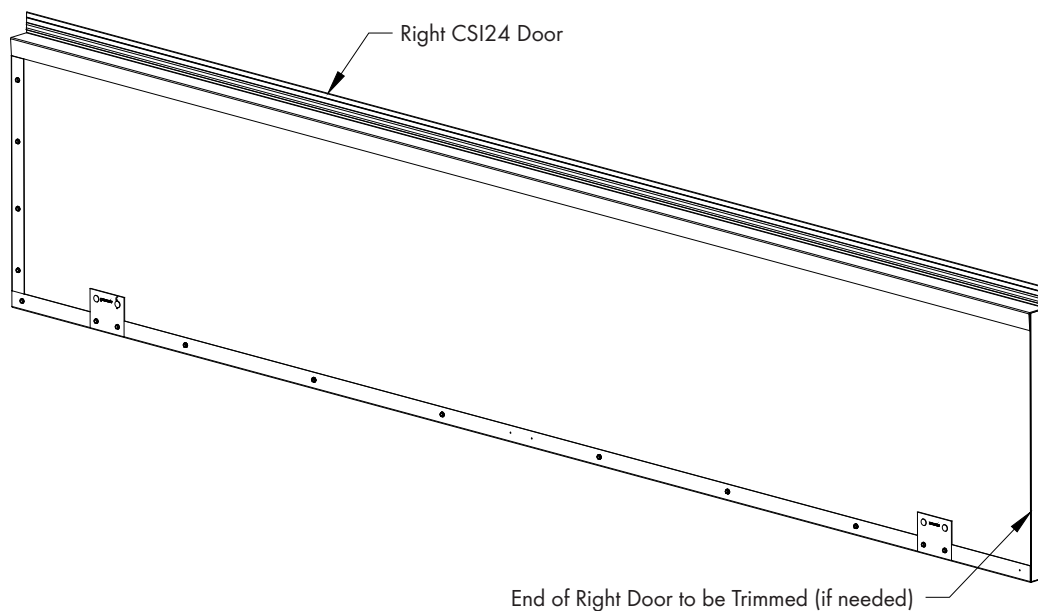

Figure 22

**Step 25**

Apply a Bead of Caulk (not provided) to the end of the Right CSI24 Door and carefully slide end of Right CSI24 Door in between the Outside Door Support and Inside Door Support on the end of Middle Door. Align Right CSI24 Door Hinge to chalk line and hold firmly against Middle CSI24 Door and attach to framing using Polebarn Screws [J] spaced 4" apart. See Figure 23.

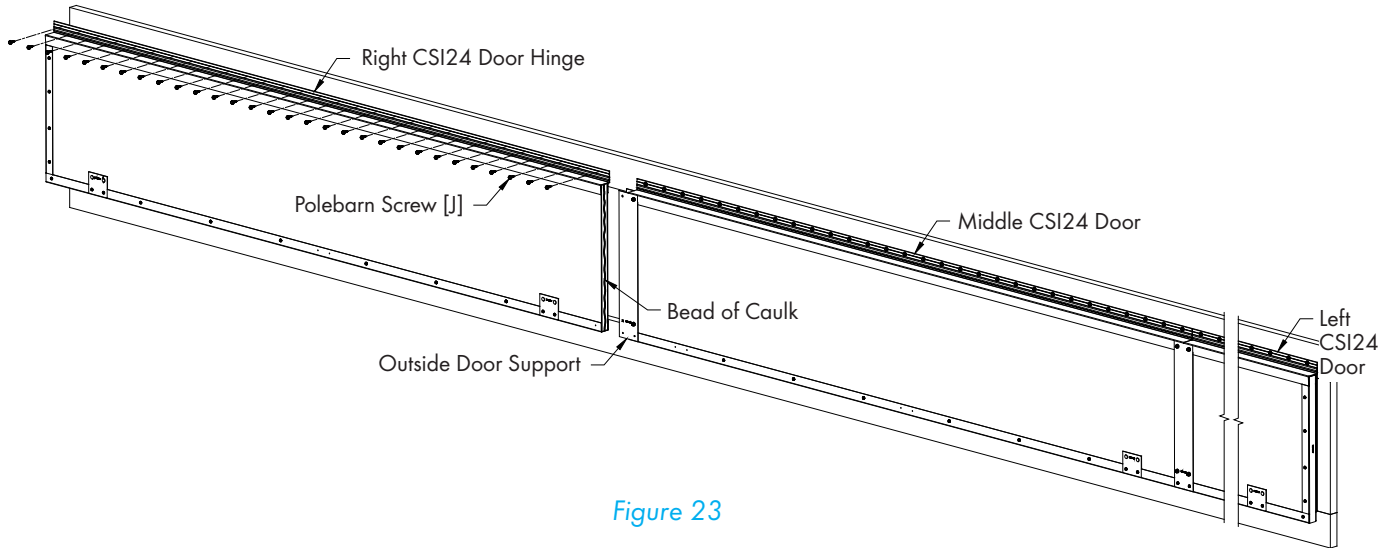

Figure 23

**Step 26**

Secure Outside Door Support from Middle Door to Right Door using (1) TEK Screws [H]. Then using the round hole and square hole as a guide, drill (2) 3/32" holes through Middle Door. See Figure 24. Make sure the drill bit goes through straight and goes through the holes in the Inside Door support.

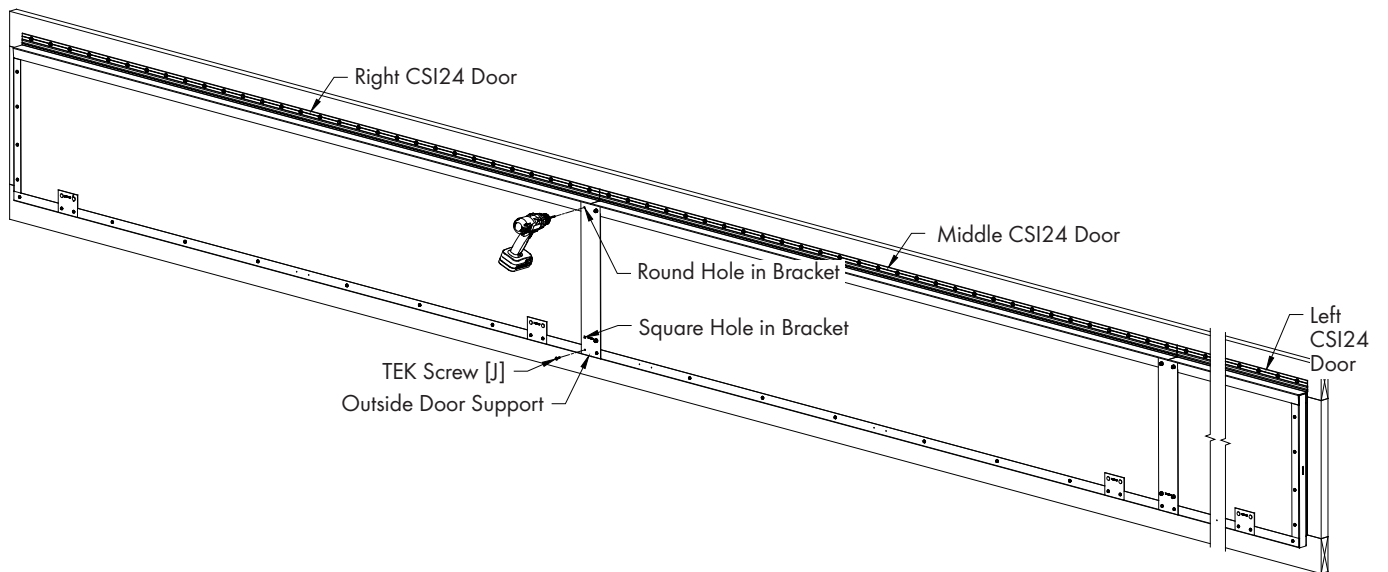

Figure 24

**Step 27**

Secure Middle and Right Doors together with (2) Carriage Bolts [F] and Nuts [E] through (2) holes in Inside and Outside Door Supports. See Figure 25. Apply a bead of caulk to the joint between doors at the hinge and the top of the doors.

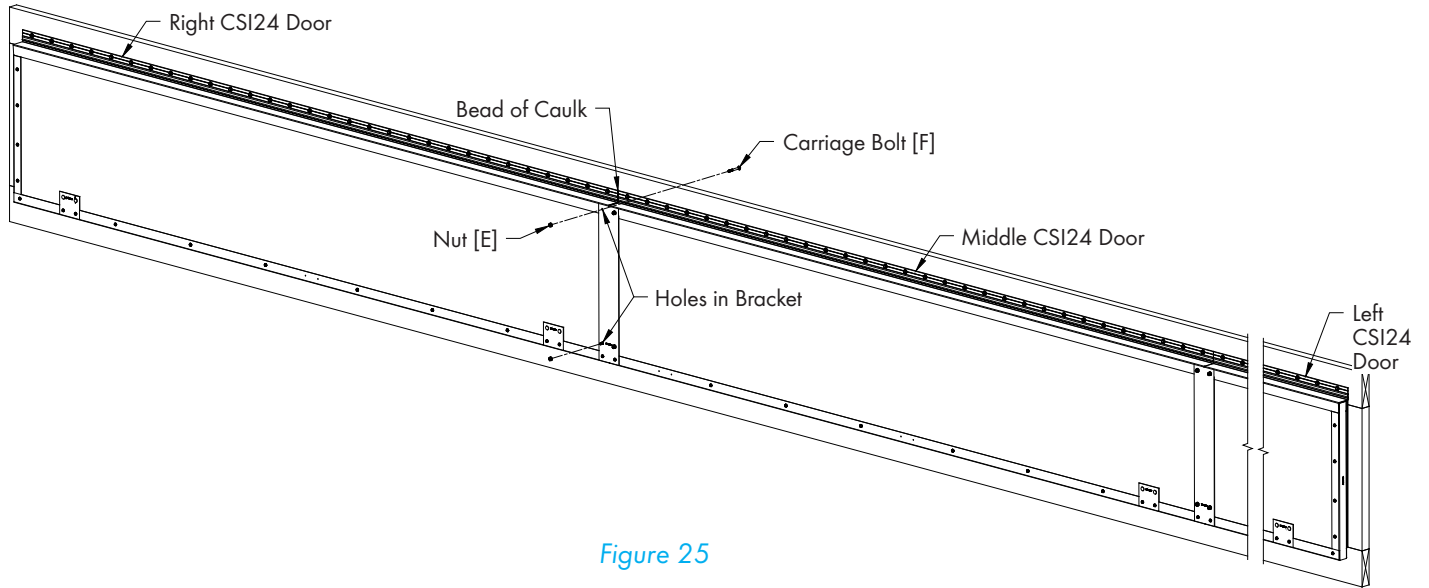

Figure 25

**Step 28**

On the bottom of the doors, at the joint between each pair of doors attach a Flat Joiner Plate [6] with (6) TEK Screws [H]. Make sure the V-Notch in the Joiner Plate is aligned with the joint in the door and (3) TEK Screws [H] go into each door. See Figure 26.

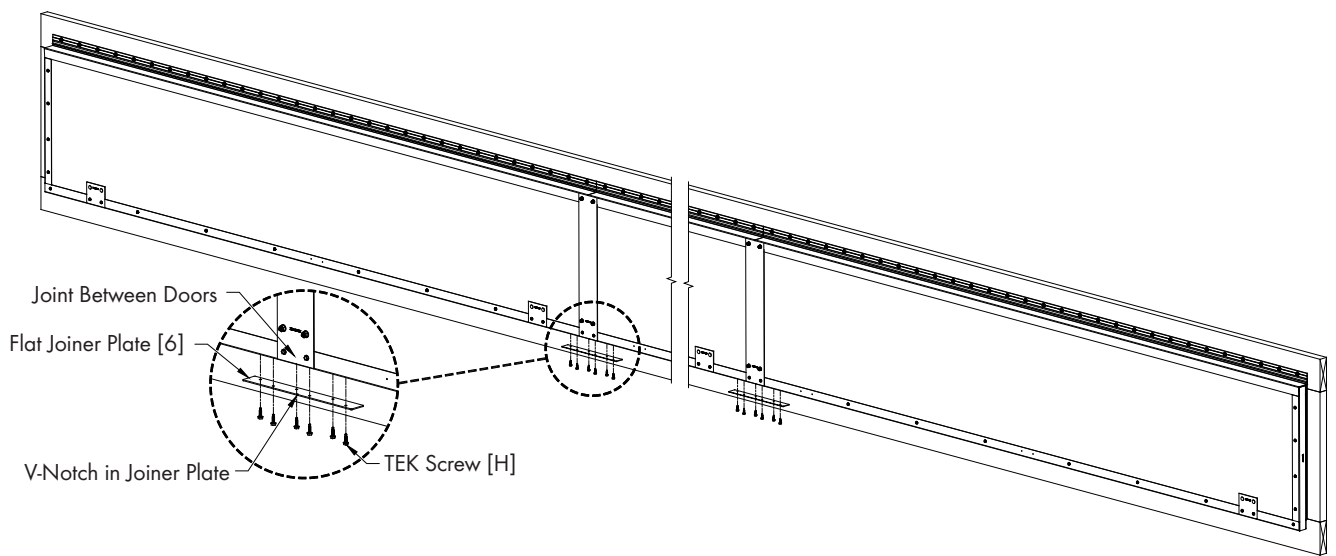

Figure 26

## 2.8 Actuator Installation

### Step 29

Attach Actuator to actuator framing using (4)  $\frac{3}{8}$ " Lag Screws [L]. See Figure 27.

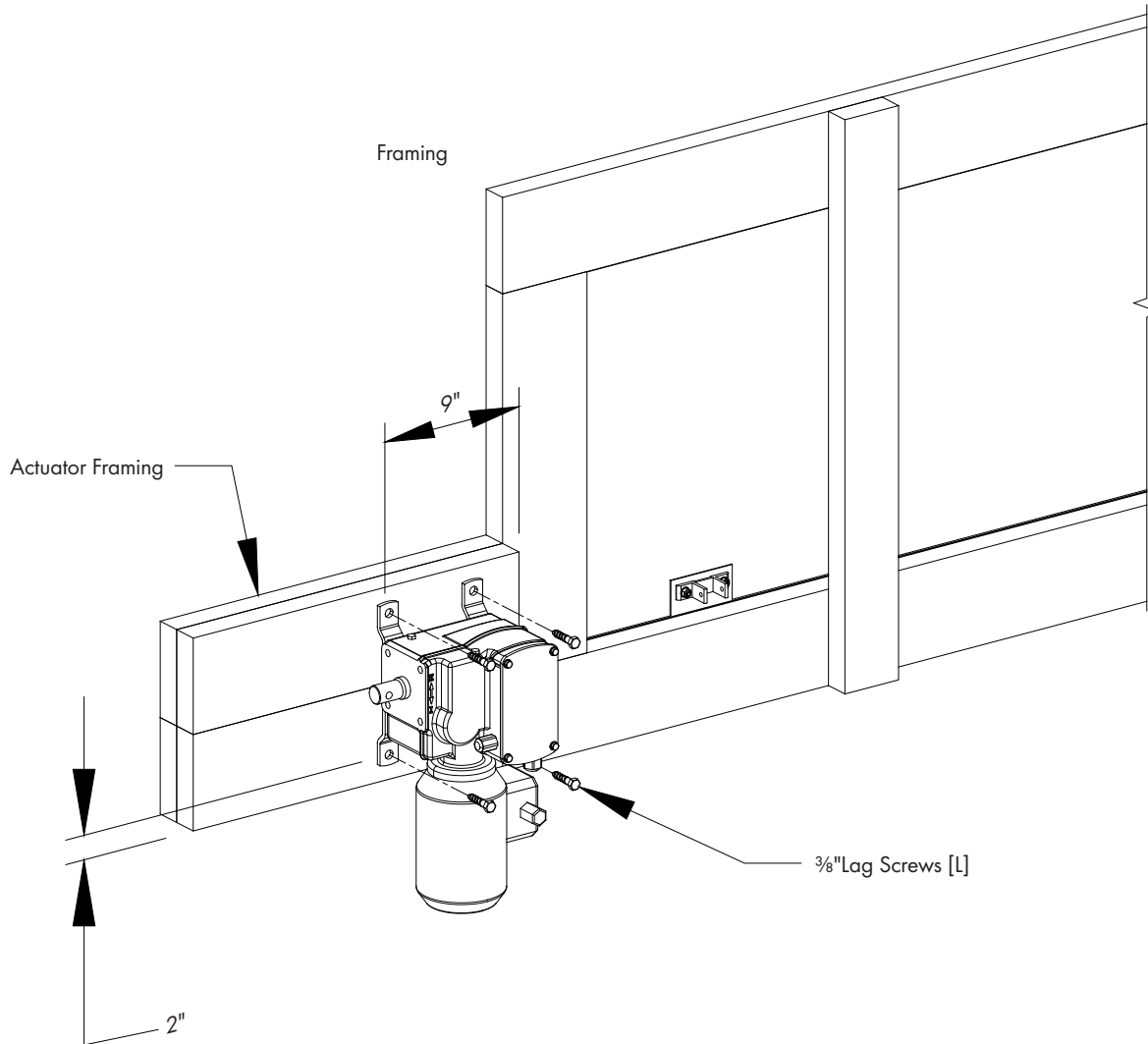

Figure 27

**Step 30**

Secure (1) Guide Plate [13] to each 2x4 framing using (2) 1/4" Lag Screws [K], 4" above the top of the bottom framing. See Figure 28.

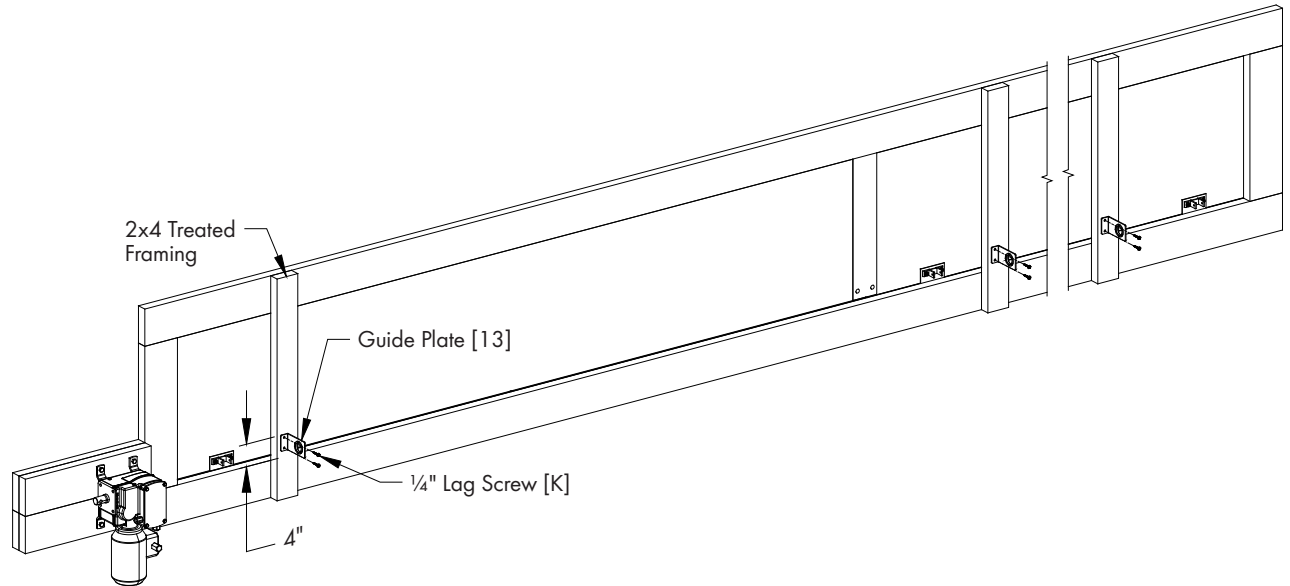

Figure 28

## 2.9 Drive Pipe Preparation

**Step 31**

For the 126"L. Drive Pipe [3] that will be at the actuator end, slide the Straight Coupling [16] over the large end of the pipe so that the (2) holes are over the pipe. Then using these holes as a guide, drill (2) pilot holes through the pipe and then drill (2) 1 3/32" dia. holes through the pipe. See Figure 29.

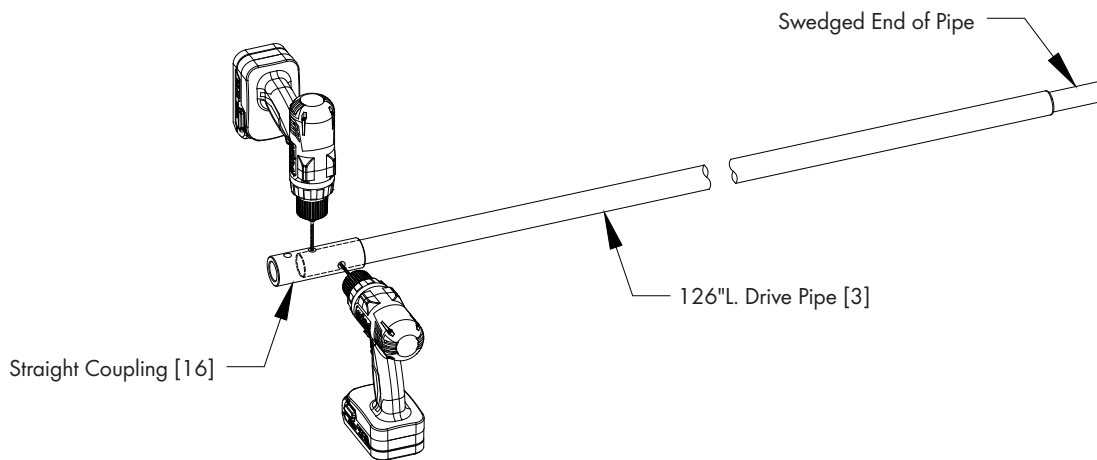

Figure 29

**Step 32**

For the next Drive Pipe [3], slide the large end over the swaged end of the previous pipe and drill a  $1\frac{3}{32}$ " dia. hole through the 2 pipes,  $1\frac{1}{2}$ " from the end of the large pipe. Continue this for all the pipes in system. [See Figure 30](#). Set all drilled pipe aside for later installation. It may be helpful to mark each pipe as it is drilled so that when they are installed the pipes that are pre-drilled together will be installed together.

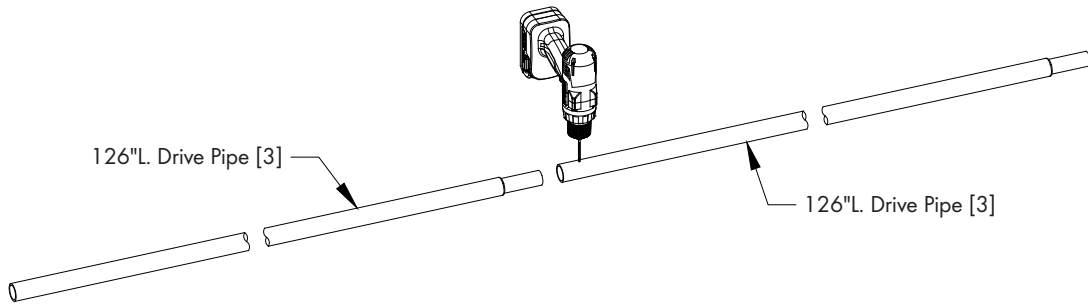

Figure 30

**2.11 Drive Pipe Installation****Step 33**

Install (2) Set Screws [C] in each Pinion Gear [7]. [See Figure 31A](#). Slide (1) Pinion Gear with Set Screws onto the first pre-drilled Drive Pipe [3]. [See Figure 31B](#). Each Pinion Gear will eventually line-up with each Door Support CHNL Bracket [6].

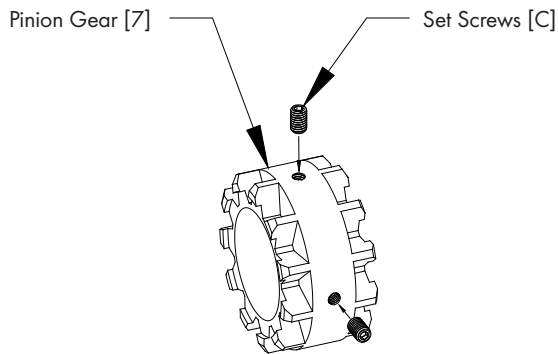

Figure 31A

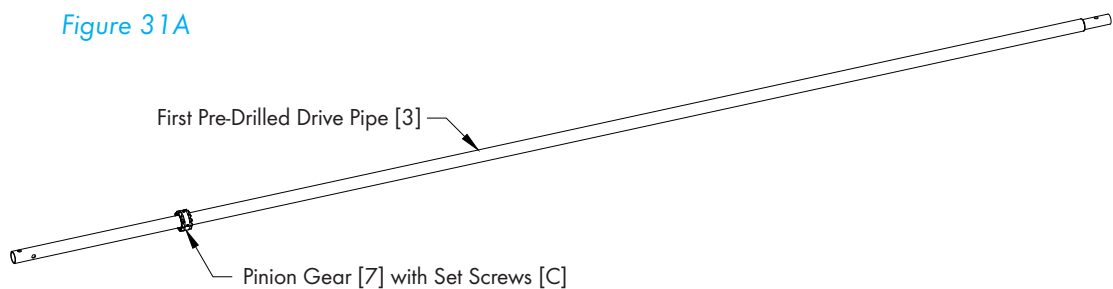

Figure 31B

**Step 34**

For the first Drive Pipe [3] with Pinion Gear, slide the swaged end of the Drive Pipe through the Bronze Bushing in Guide Plate [13] so that the 1 Pinion Gear is on the left side of the Guide Plate [13] in line with Pivoting Connector. See Figure 32.

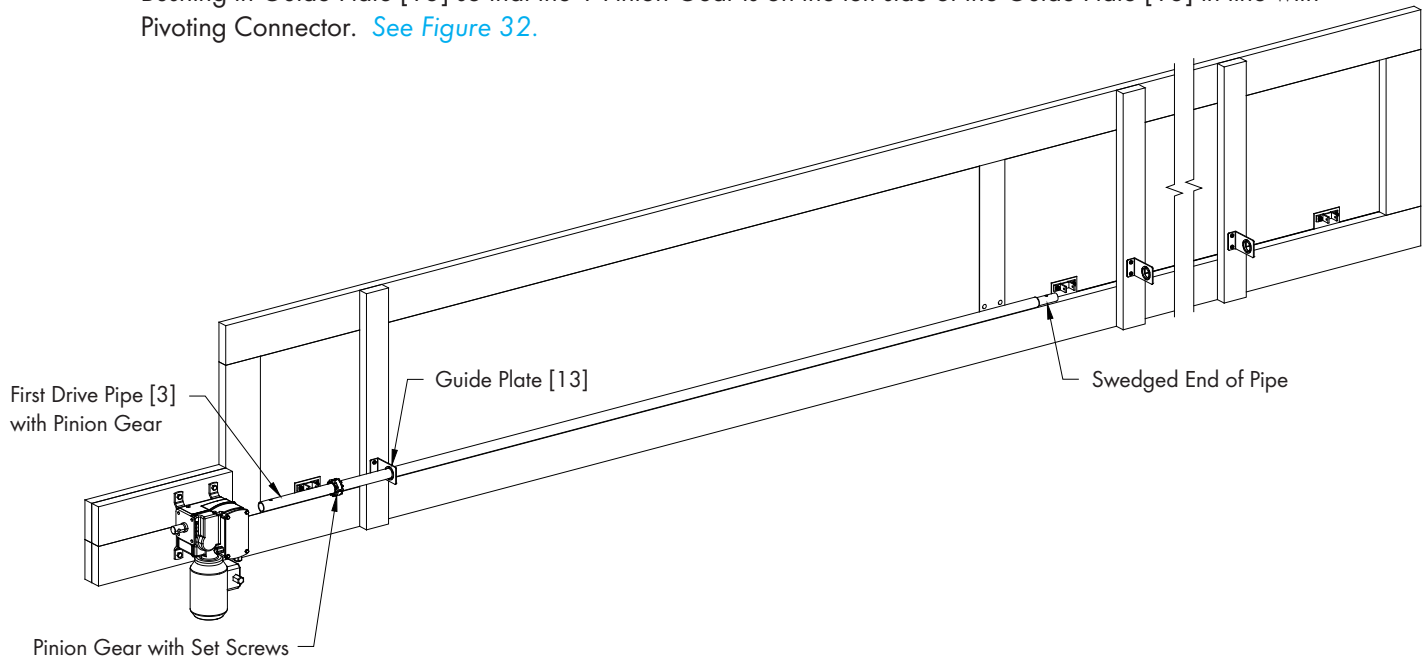

Figure 32

**Step 35**

For next Drive Pipe [3] slide (1) Pinion Gear onto Pipe, then slide the swaged end of the Drive Pipe through the next Bronze Bushing in Guide Plate [13]. Then slide the opposite end onto the swaged end of the previous pipe. If needed slide the Pinion Gear past the joint in the pipes to align with the Pivoting Connector. Align the pre-drilled holes and secure pipes together using Bolt [D] and Nut [G]. See Figure 33. Repeat this step for all but the last Drive Pipe [3].

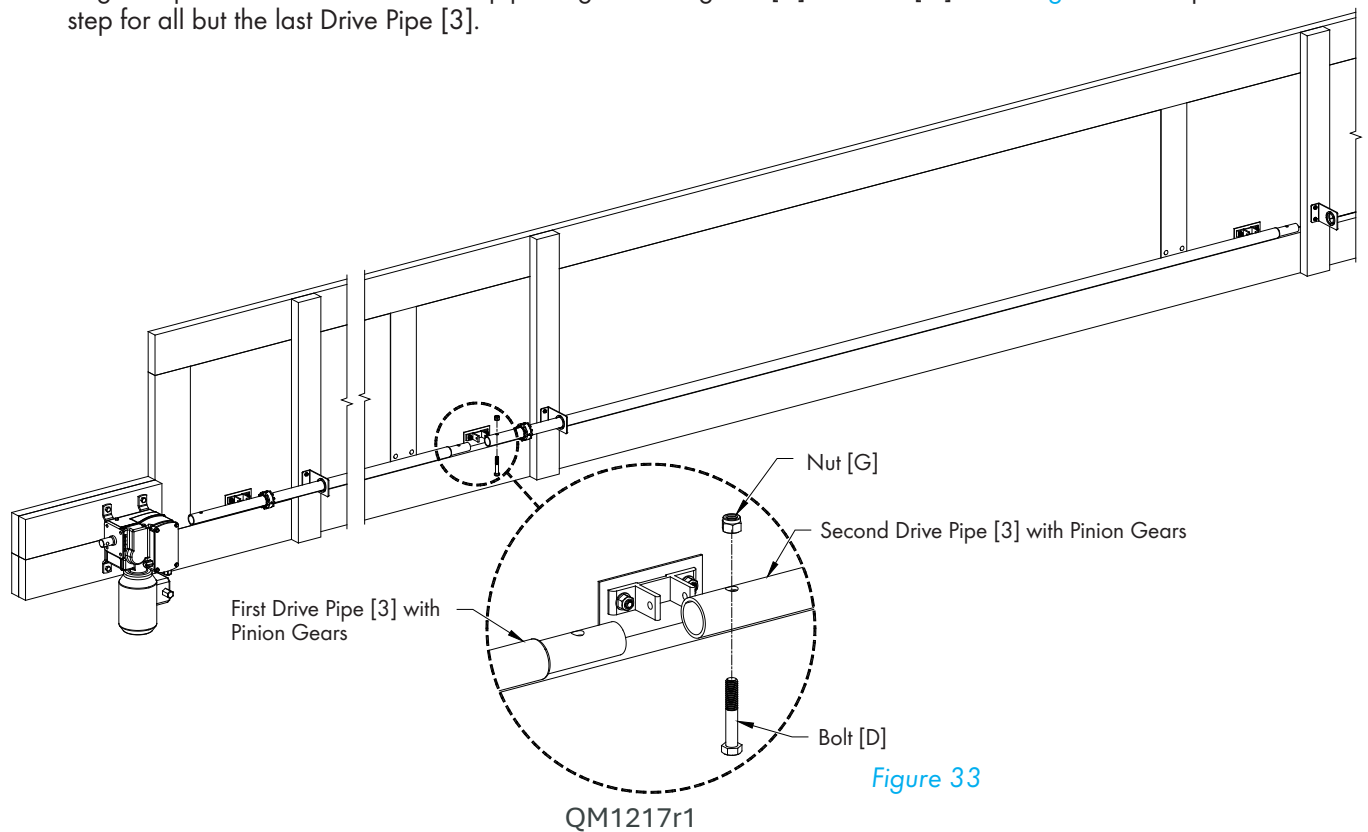

Figure 33

Step 36

The last Drive Pipe [3] requires (2) Pinion Gears on the Pipe. Slide the Drive Pipe into the Bronze Bushing in last (2) Guide Plates [13], there will be one Pinion Gear lined up with each Pivoting Connector. Slide the opposite end onto the swedged end of the previous pipe. If needed slide one of the Pinion Gears past the joint in the pipes to align with the Pivoting Connector. Align the pre-drilled holes and secure pipes together using Bolt [D] and Nut [G]. See Figure 34. Cut excess Drive Pipe 3" past the last Pinion Gear.

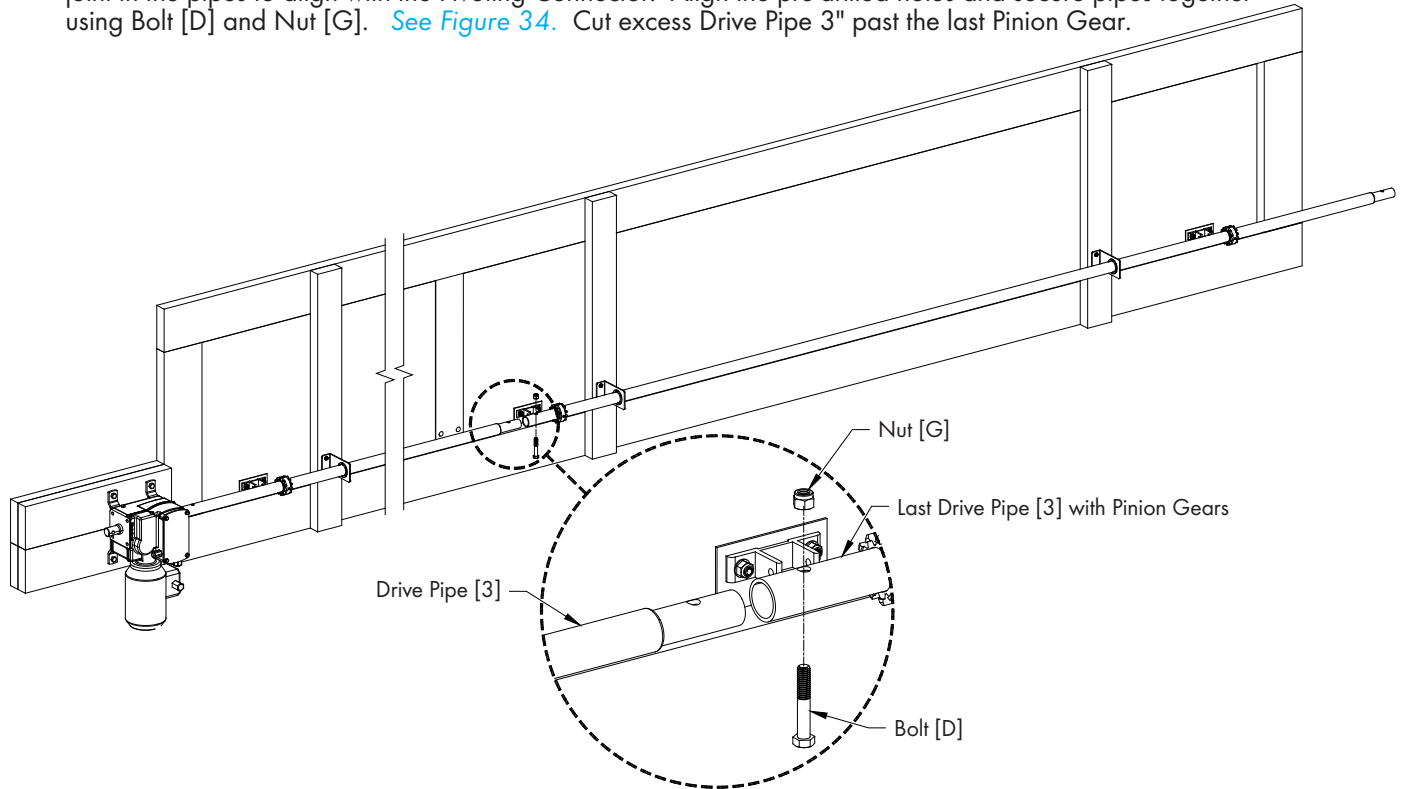

Figure 34

Step 37

Slide the Straight Coupling [17] over the end of the pipe near the Actuator and secure in place using (2) Bolts [D] and Nuts [G]. See Figure 35.

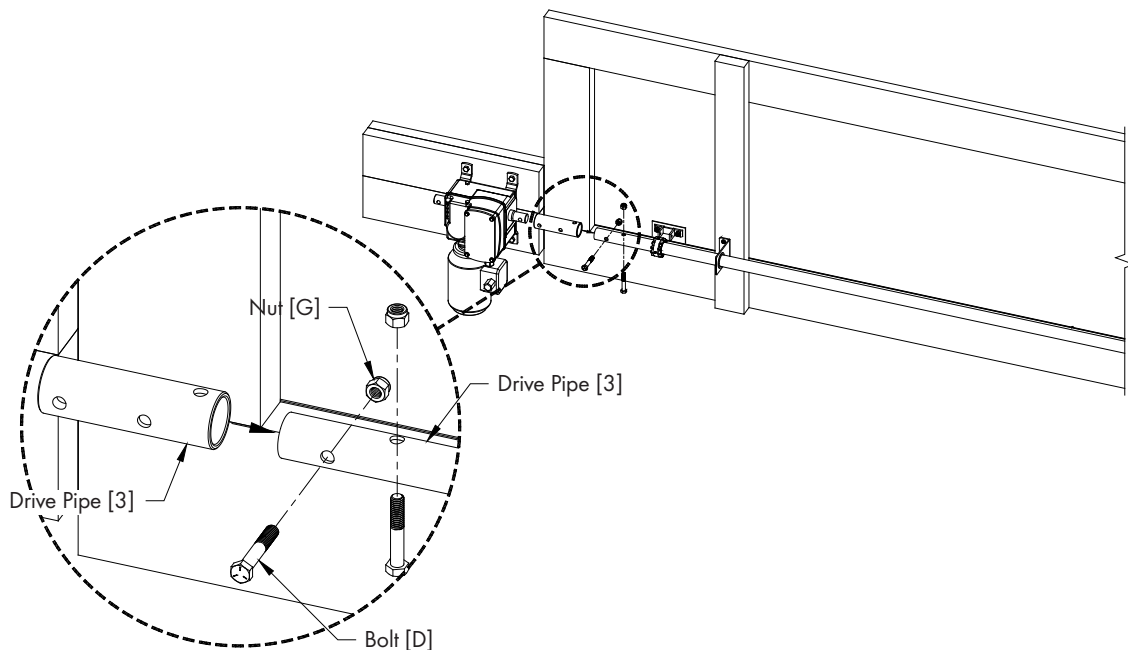

Figure 35

QM1217r1

**Step 38**

Align the hole in the Straight Coupling on Drive Pipe with the hole in the Shaft of Actuator and secure with (1) Bolts [D] and Nuts [G]. See Figure 36.

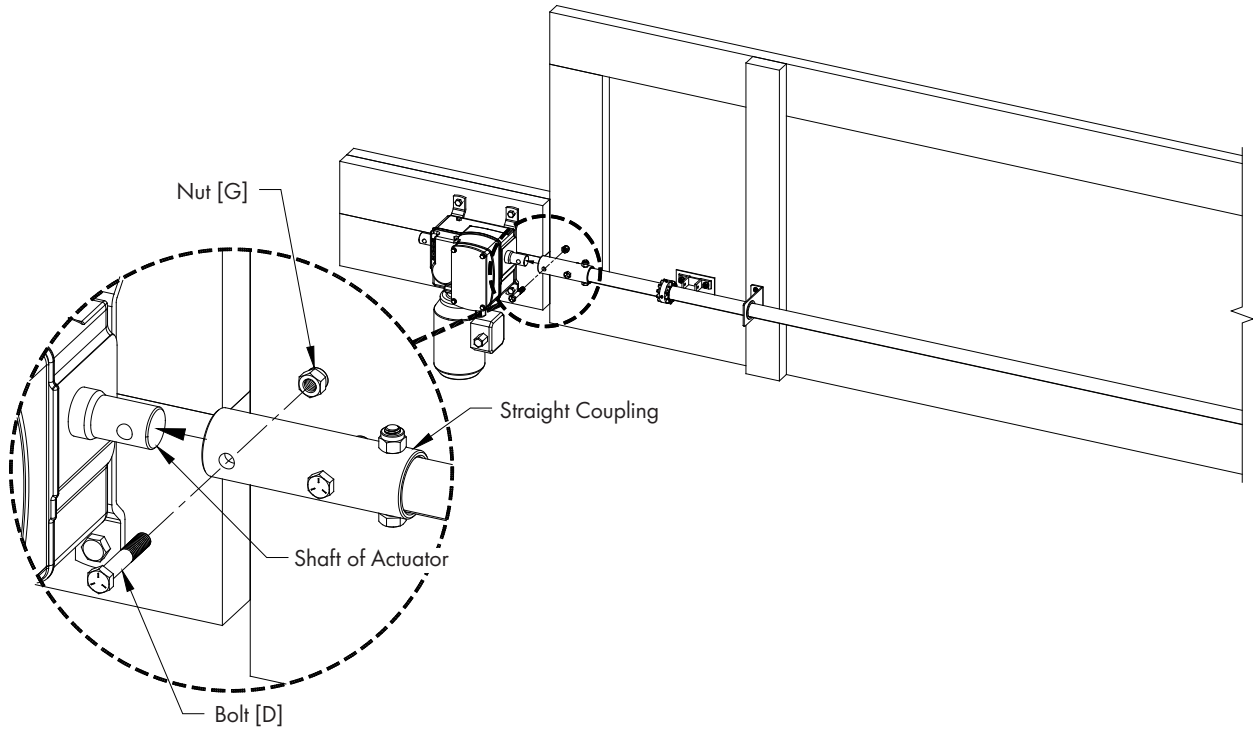

Figure 36

**Step 39**

Align each Pinion Gear with Set Screws with a Pivoting Connector on the Door below the Drive Pipe. See Figure 37.

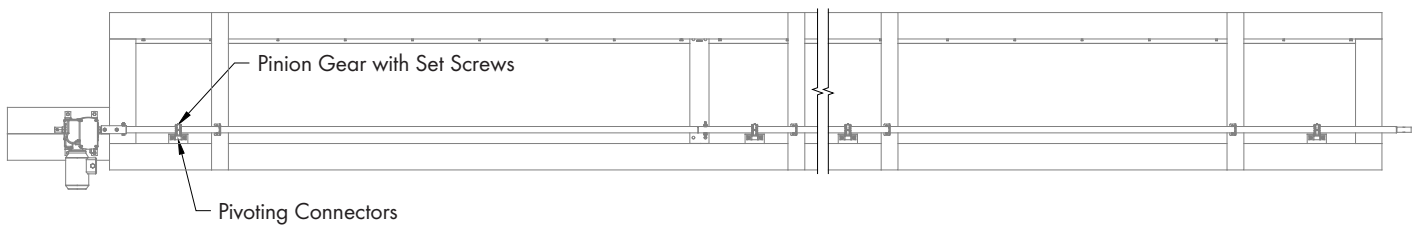
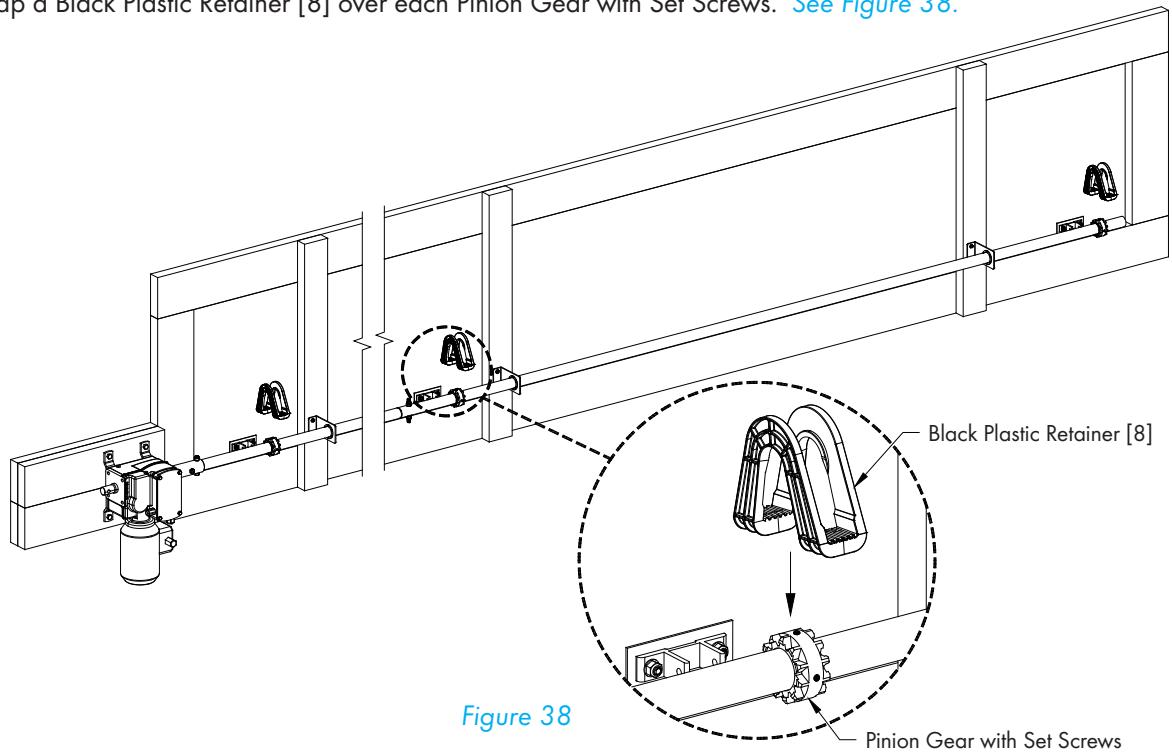

Figure 37

Step 40

Snap a Black Plastic Retainer [8] over each Pinion Gear with Set Screws. See Figure 38.



Step 41

Rotate one of the Plastic Retainer/Pinion Gear assemblies 90° so that the flat part is away from door and insert end of Straight Rack [5] with no teeth into Retainer/Gear Assembly and slide it in until the teeth on the Straight Rack [5] engage the Pinion Gear. Rotate the Straight Rack towards the bottom of the door and fasten the end of the Straight Rack [5] to the Pivoting Connector [9] using Clevis Pin [A] and Hairpin Cotter [B]. See Figure 39. If Curved Racks were purchased See Figure 40 on next page.

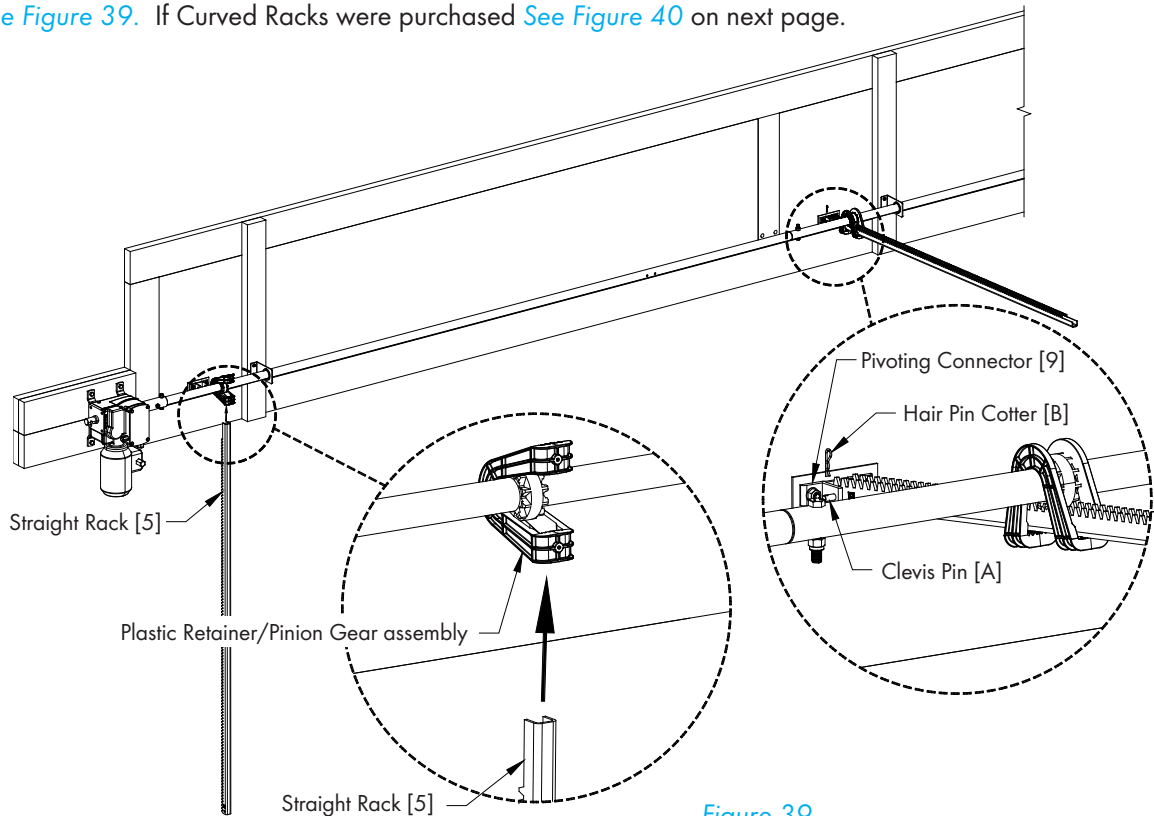

QM1217r1

## Step 41 (continued)

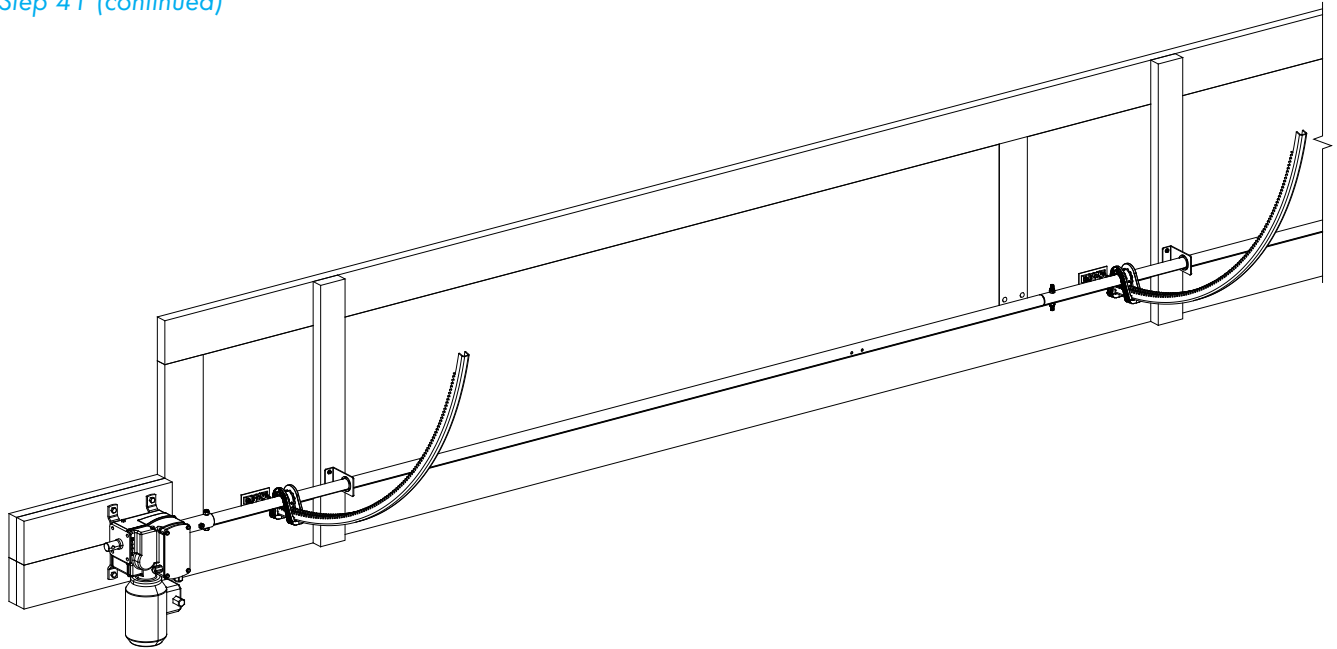

Figure 40

## Step 42

Make sure each Plastic Retainer/Pinion Gear is lined up with each Pivoting Connector and the Straight Rack or Curved Rack is as straight as possible. Tighten the Set Screws on each Pinion Gear on the Drive Pipe. It may be necessary to unhook the Straight or Curved Rack from the Pivoting Connector, slide the Rack out of the Plastic Retainer to be able to rotate the Pinion Gear slightly to be able to access both Set Screws. Then slide the Rack back into the Plastic Retainer and reconnect it to the Pivoting Connector. See Figure 41.

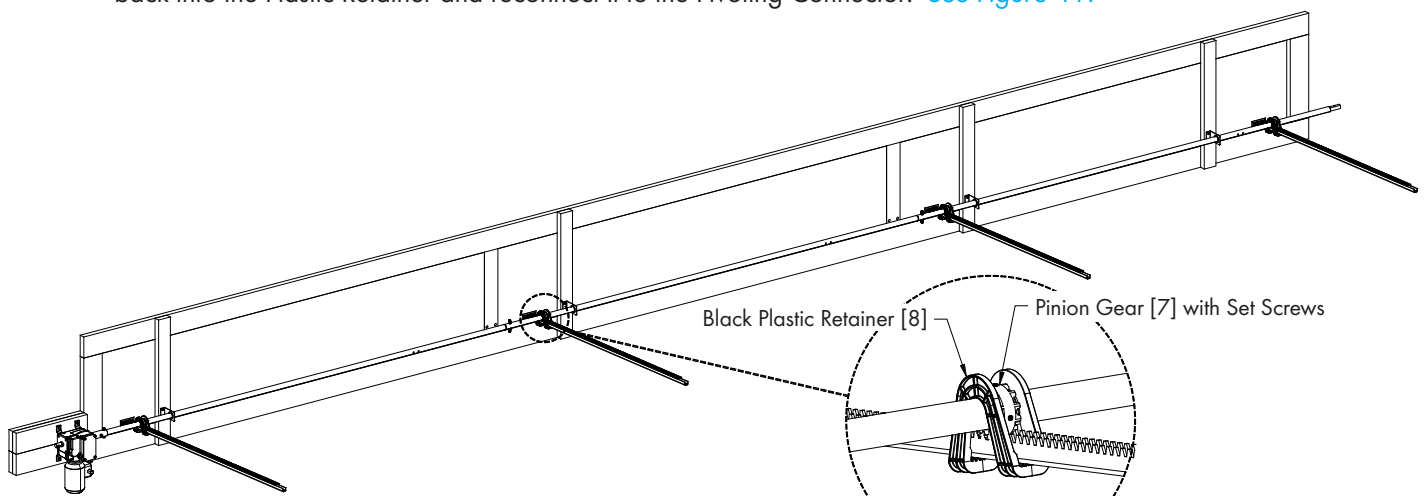

Figure 41

## Step 43

Before operating the system, use Tubes of Grease provided to lightly grease the Pinion Gear and the back of the Rack where it slides through the Black Plastic Retainer.

See Actuator Manual for wiring instructions.

## 3.1 Maintenance

The following inspection and cleaning procedures should be performed monthly:

- 1) **STRAIGHT/CURVED RACKS:** Check for wear on the rack, especially on the teeth and the pinion gear. Reapply Grease to the Pinion Gear and Straight Rack once a year.
- 2) **CLEAN** regularly for best results:
  - **ACTUATOR:** Remove any dust accumulation from actuator using a brush or cloth. (DO NOT use a pressure washer).
  - **STRAIGHT/CURVED RACKS:** Carefully clean dust from racks and frame so that racks open and close doors freely. A brush or cloth should be used.
  - **DOORS:** Clean any dust or feathers from doors using a brush.
- 3) **CHECK FASTENERS:** For safety, all fasteners should be inspected 1 month after initial operation and yearly thereafter. Tighten any loose connections.
- 4) **INSPECT INLET CONTROL:** With power disconnected, inspect all electrical connections. Wiring should be secure and in good condition. Remove any dust build-up from control case and sensor using a soft brush or cloth. **NEVER CLEAN ELECTRICAL EQUIPMENT WITH A PRESSURE WASHER!**

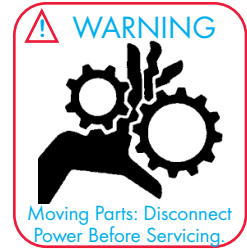

**This page left blank intentionally**



Munters Aerotech CSI24 Continuous Sidewall Inlet Flush Mount is developed and produced by GrainProteinTech Climate Control Air Treatment US, LLC.

2691 Ena Dr., Lansing, MI 48917 | 1-800-227-2376

© 2025 GRAIN AND PROTEIN TECHNOLOGIES.

All rights reserved. GrainProteinTech Climate Control & Air Treatment reserves the right to change designs and specifications without notice.

[www.climatecontrolairtreatment.com](http://www.climatecontrolairtreatment.com)